

---

## DESPIECES DEL SERVICIO TECNICO

---

### **SERIE 900**

#### Sartén Basculante

<del>SBG9-10</del>	SBE9-10
<del>SBG9-10 I</del>	SBE9-10 I
<del>SBG9-10 M</del>	SBE9-10 M
<del>SBG9-10 IM</del>	SBE9-10 IM
<del>SBG9-15 IM</del>	SBE9-15 IM
<del>SBG9-15 IMS</del>	SBE9-15 IMS



**PLATON SERVICE**  
8 (800) 500-3471  
[www.platonservice.com](http://www.platonservice.com)

**ENERO, 1999**



Fagor Industrial, S. Coop.

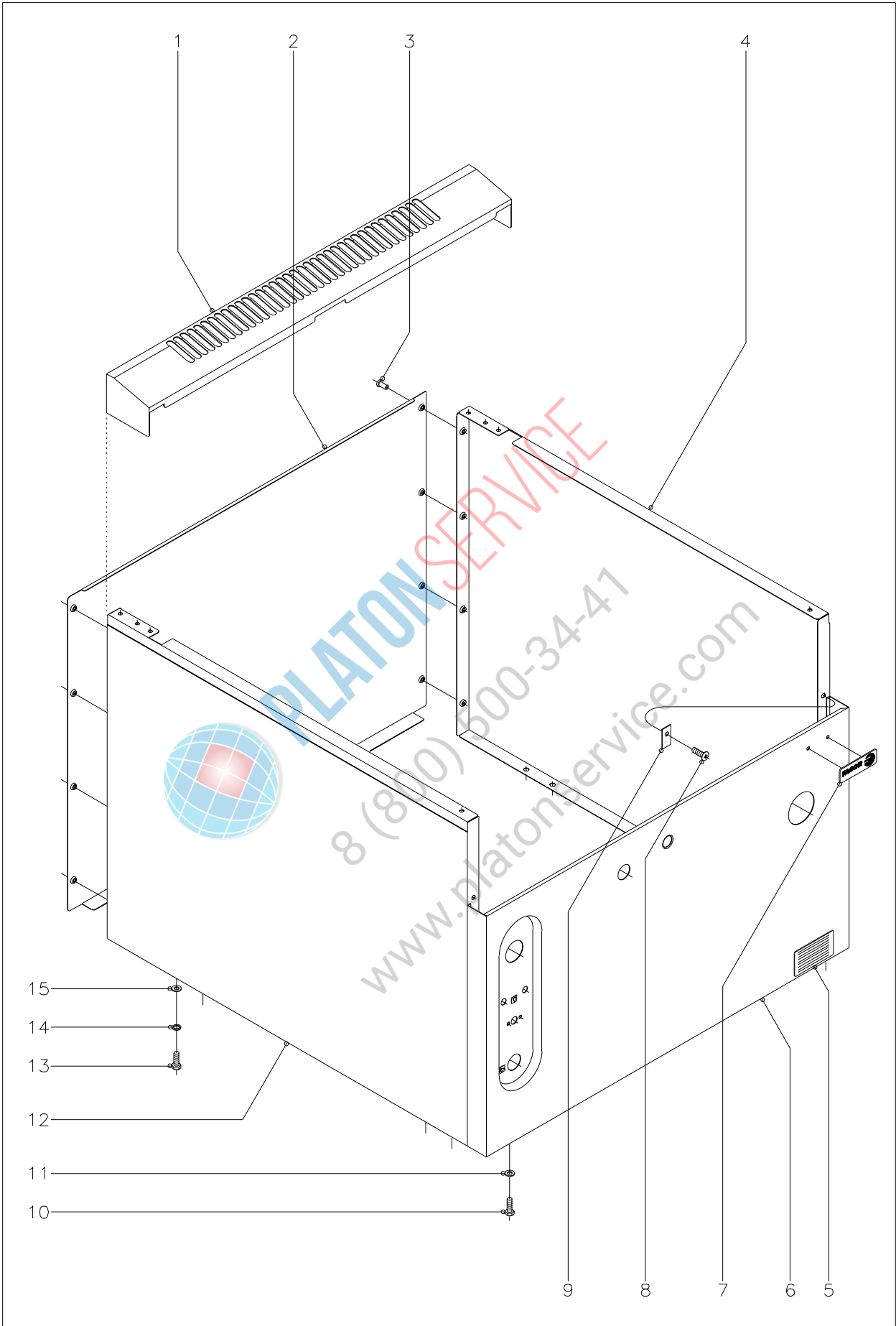

PLATON SERVICE  
 8 (800) 500-34-47  
 www.platonservice.com

N plano C-649	Firma 	Fecha 1-99	Aparato AL SUELO SARTEN BASCULANTE 900	Lamina 1	Fagor Industrial S.Coop. Ocate	
------------------	-----------	---------------	--	-------------	-----------------------------------	--



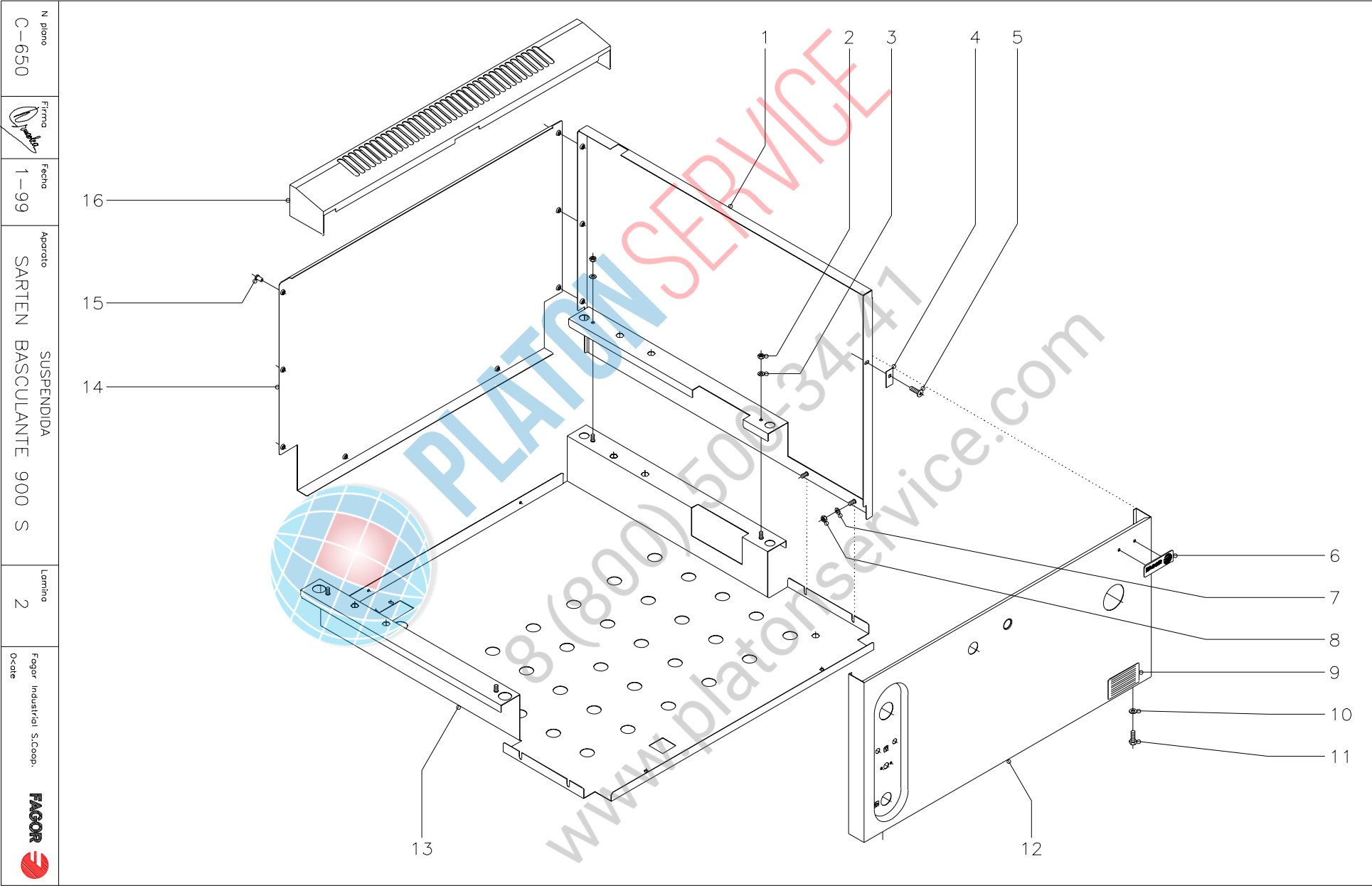

N plano	C-650
Firma	
Fecha	1-99
Aparato	SUSPENDIDA SARTEN BASCULANTE 900 S
Laminas	2
Fagor Industrial S.Coop. O-date	

MOD.

SBG9-10  
SBG9-15SBE9-10  
SBE9-15

Versiones: I, M, S.

ZONA

MUEBLE EXTERIOR

PLANO

C-650

Nº	CODIGO	DENOMINACION	SBG 9-10 S	SBG 9-10 IS	SBE 9-10 S	SBE 9-10 IS							NOTAS
1	X242813	Panel lateral derecho	1	1	1	1							
s/n	X242811	Panel lateral izquierdo	1	1	1	1							
2	Q162030	Tuerca exagonal M.5	4	4	4	4							
3	Q302022	Arandela plana Ø16xØ6x1,2	4	4	4	4							
4	X152811	Soporte panel frontal	1	1	1	1							
5	Q152004	Tornillo aplastado M.5x13	1	1	1	1							
6	U262806	Escudo FAGOR	1	1	1	1							
s/n	Q221023	Clip sujeción escudo	2	2	2	2							
7	Q302022	Arandela plana Ø16xØ6x1,2	4	4	4	4							
8	Q162030	Tuerca exagonal M.5	4	4	4	4							
9	S326530	Placa matrícula	1	1	-	-							
9	Z206121	Placa matrícula	-	-	1	1							
10	Q302022	Arandela plana Ø16xØ6x1,2	2	2	2	2							
11	Q012042	Tornillo exagonal M.6x15	2	2	2	2							
12	X242816	Panel frontal	1	1	-	-							
12	X252801	Panel frontal	-	-	1	1							
13	X242814	Base inferior	1	1	-	-							
13	X252802	Base inferior	-	-	1	1							
14	X242817	Panel posterior	1	1	1	1							
15	Q419005	Remache tubular Ø4x8	8	8	8	8							
16	R165432	Embellecedor bajo 1M.	1	1	1	1							

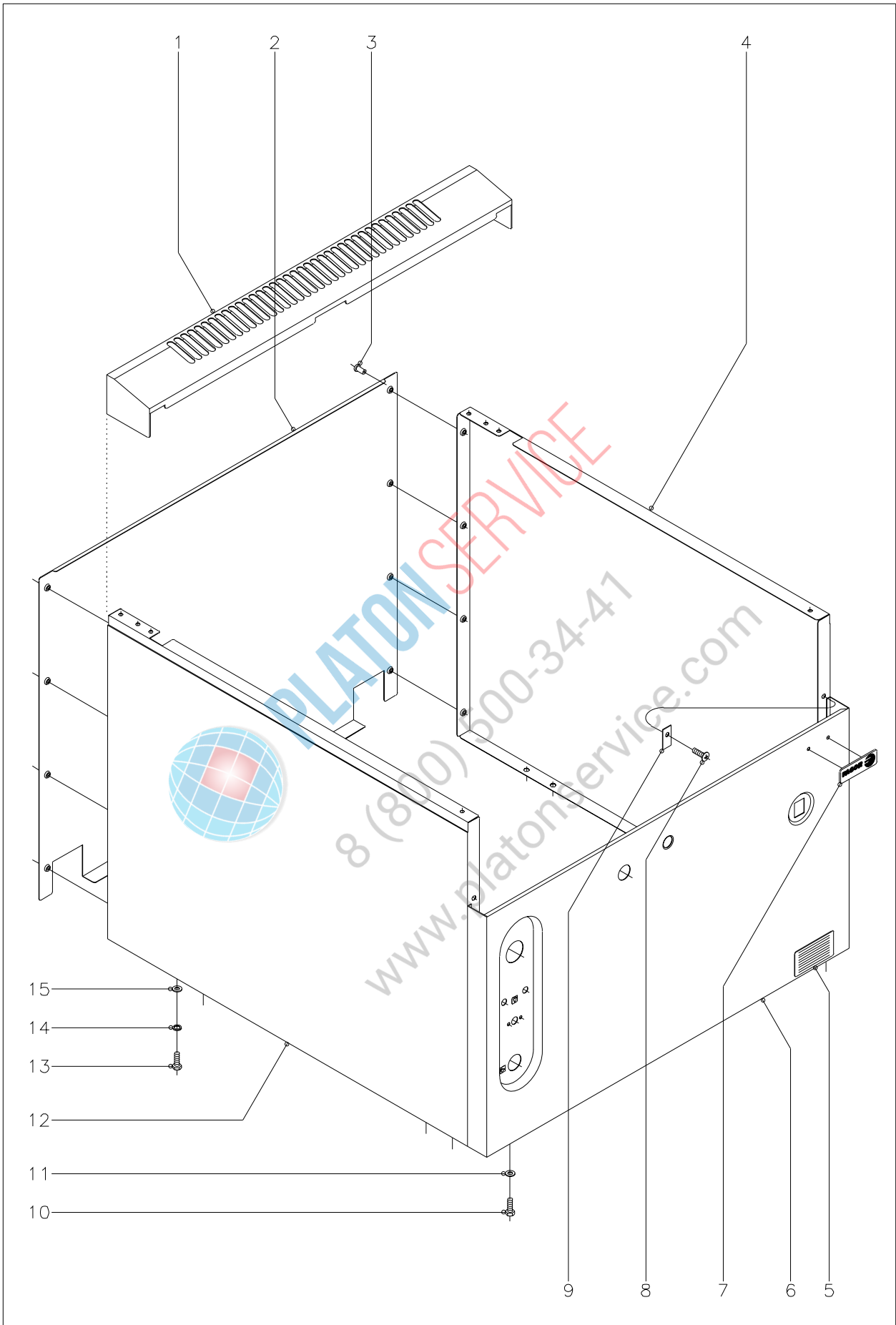

N plano C-651	Firma 	Fecha 1-99	Aparato SUSPENDIDA MOTORIZADA SARTEN BASCULANTE 900	Lamina 3	Fagor Industrial S.Coop. <b>FAGOR</b> 0<ate
------------------	--	---------------	---	-------------	--

MOD.

SBG9-10  
SBG9-15SBE9-10  
SBE9-15

Versiones: I, M, S.

ZONA

MUEBLE EXTERIOR

PLANO

C-651

Nº	CODIGO	DENOMINACION	SBG	SBG	SBG	SBE	SBE	SBE					NOTAS
			9-10 MS	9-10 IMS	9-15 IMS	9-10 MS	9-10 IMS	9-15 IMS					
1	R165432	Embelecedor bajo 1M.	1	1	-	1	1	-					
1	U585450	Embelecedor bajo 11/2M.	-	-	1	-	-	1					
2	X452800	Panel posterior 1 MS	1	1	-	1	1	-					
2	X412800	Panel posterior 1 1/2 MS	-	-	1	-	-	1					
3	Q419005	Remache tubular Ø4x8	8	8	8	8	8	8					
4	X152820	Panel lateral derecho	1	1	1	1	1	1					
5	S326530	Placa matrícula	1	1	1	-	-	-					
5	Z206121	Placa matrícula	-	-	-	1	1	1					
6	X342801	Panel frontal	1	1	-	-	-	-					
6	X282810	Panel frontal	-	-	1	-	-	-					
6	X402800	Panel frontal	-	-	-	1	1	-					
6	X422800	Panel frontal	-	-	-	-	-	1					
7	U262806	Escudo FAGOR	1	1	1	1	1	1					
s/n	Q221023	Clip sujeción escudo	2	2	2	2	2	2					
8	Q152004	Tornillo aplastado M.5x13	1	1	1	1	1	1					
9	X152811	Soporte panel frontal	1	1	1	1	1	1					
10	Q012042	Tornillo exagonal M.6x15	2	2	2	2	2	2					
11	Q302022	Arandela plana Ø16xØ6x1,2	2	2	2	2	2	2					
12	X152821	Panel lateral izquierdo	1	1	1	1	1	1					
13	Q012042	Tornillo exagonal M.6x15	8	8	8	8	8	8					
14	Q262040	Arandela muelle A.6	8	8	8	8	8	8					
15	Q302022	Arandela plana Ø16xØ6x1,2	8	8	8	8	8	8					

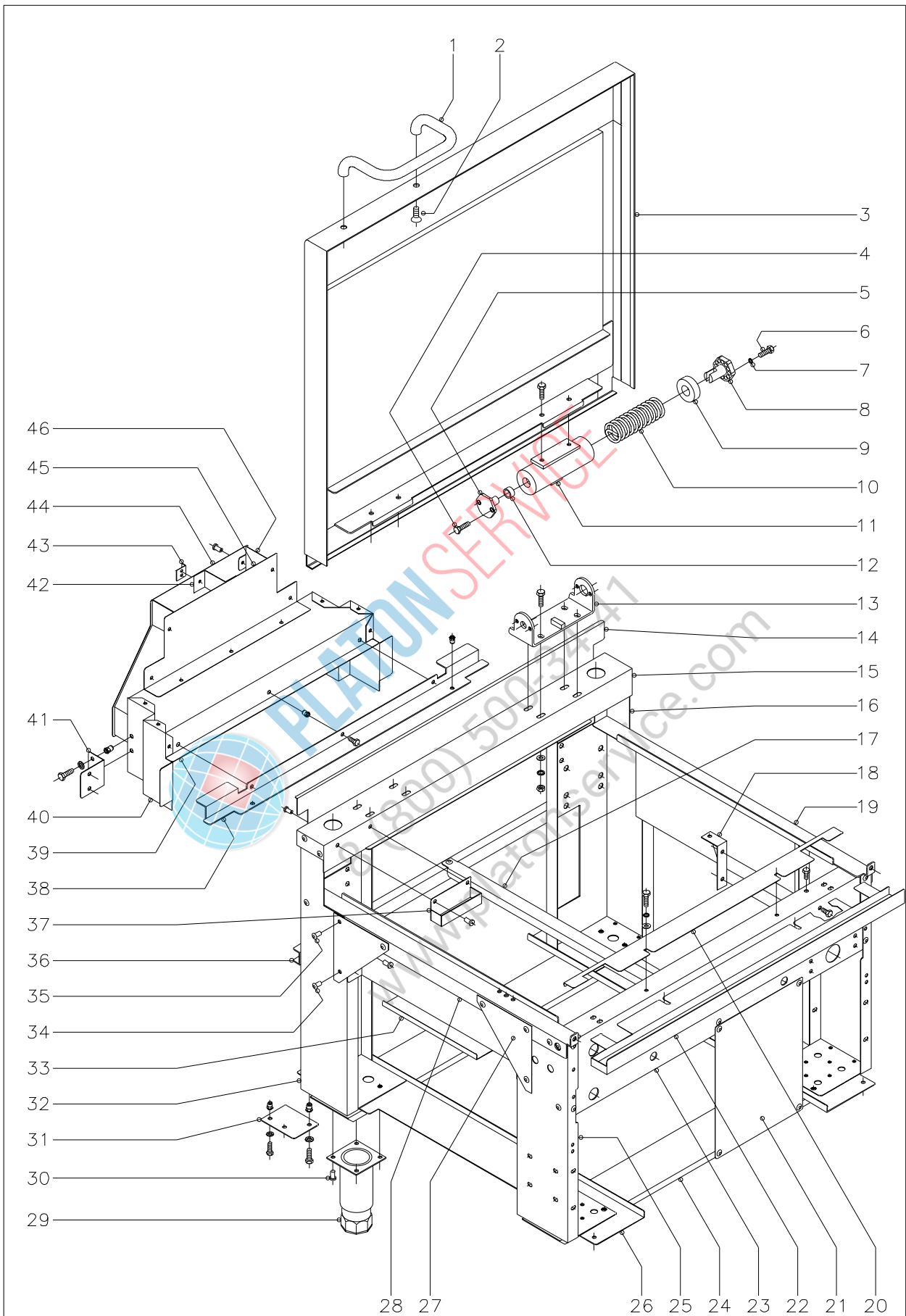

N plano C-652	Firma 	Fecha 1-99	Aparato AL SUELO SARTEN BASCULANTE 900	Lamina 4	Fagor Industrial S.Coop. <b>FAGOR</b> D'cate
------------------	--	---------------	--	-------------	---



<b>MOD.</b>	<b>SBG9-10</b> <b>SBG9-15</b>	<b>SBE9-10</b> <b>SBE9-15</b>	<b>ZONA</b>	<b>DESPIECE ARMAZON,</b> <b>CHIMENEA Y TAPA</b>	<b>PLANO</b>	<b>C-652</b>
	<b>Versiónes: I, M, S.</b>					

Nº	CODIGO	DENOMINACION	SBG 9-10	SBG 9-10 I	SBG 9-10 M	SBG 9-10 IM	SBG 9-15 IM	SBE 9-10	SBE 9-10 I	SBE 9-10 M	SBE 9-10 IM	SBE 9-15 IM	NOTAS
1	S036123	Asa de tapa	1	1	1	1	1	1	1	1	1	1	
2	Q062036	Tornillo avellanado M.8x20	2	2	2	2	2	2	2	2	2	2	
3	X152823	Tapa	1	1	1	1	-	1	1	1	1	-	
3	X282812	Tapa	-	-	-	-	1	-	-	-	-	1	
4	Q012041	Tornillo exagonal M.6x10	4	4	4	4	4	4	4	4	4	4	
5	S116119	Giro de asa	2	2	2	2	2	2	2	2	2	2	
6	Q012042	Tornillo exagonal M.6x15	4	4	4	4	4	4	4	4	4	4	
7	Q262040	Arandela muelle A.6	4	4	4	4	4	4	4	4	4	4	
8	S116120	Tensor resorte	2	2	2	2	2	2	2	2	2	2	
9	S116118	Casquillo	2	2	2	2	2	2	2	2	2	2	
10	S116121	Resorte tapa	2	2	2	2	2	2	2	2	2	2	
11	X156101	Bisagra	2	2	2	2	2	2	2	2	2	2	
	Q012051	Tornillo exagonal M.8x10	4	4	4	4	4	4	4	4	4	4	
12	S116126	Cojinete cilíndrico	2	2	2	2	2	2	2	2	2	2	
13	X286102	Soporte de bisagra	2	2	2	2	2	2	2	2	2	2	
	Q012053	Tornillo exagonal M.8x20	8	8	8	8	8	8	8	8	8	8	
	Q232050	Arandela plana A.8	8	8	8	8	8	8	8	8	8	8	
	Q262050	Arandela muelle A.8	8	8	8	8	8	8	8	8	8	8	
	Q162050	Tuerca exagonal M.8	8	8	8	8	8	8	8	8	8	8	
14	X152638	Listón posterior	1	1	1	1	-	1	1	1	1	-	
14	X282613	Listón posterior	-	-	-	-	1	-	-	-	-	1	
	Q419005	Remache tubular Ø4x8	5	5	5	5	5	5	5	5	5	5	
15	X140125	Cubierta puente	1	1	1	1	-	1	1	1	1	-	
15	X280104	Cubierta puente	-	-	-	-	1	-	-	-	-	1	
16	X140122	Poste posterior derecho	1	1	-	-	-	1	1	-	-	-	
16	X340101	Poste posterior derecho	-	-	1	1	1	-	-	1	1	1	
17	X140128	Listón refuerzo	-	-	-	-	-	1	1	-	-	-	
	Q411304	Remache avibulb Ø 4,8	-	-	-	-	-	2	2	-	-	-	
18	X142618	Refuerzo sartén	2	2	2	2	2	2	2	2	2	2	
	Q012042	Tornillo exagonal M.6x15	6	6	6	6	6	6	6	6	6	6	
19	X140126	Apoyo de cuba derecho	1	1	1	1	1	1	1	1	1	1	

<b>MOD.</b>	<b>SBG9-10</b>	<b>SBE9-10</b>	<b>ZONA</b>	<b>DESPIECE ARMAZON, CHIMENEA Y TAPA</b>	<b>PLANO</b>	<b>C-652</b>
	<b>SBG9-15</b>	<b>SBE9-15</b>				
	<b>Versiónes: I, M, S.</b>					

Nº	CODIGO	DENOMINACION	SBG 9-10	SBG 9-10 I	SBG 9-10 M	SBG 9-10 IM	SBG 9-15 IM	SBE 9-10	SBE 9-10 I	SBE 9-10 M	SBE 9-10 IM	SBE 9-15 IM	NOTAS
20	X152645	Freno de humos	1	1	1	1	-	-	-	-	-	-	
20	X282617	Freno de humos	-	-	-	-	1	-	-	-	-	-	
21	X140129	Refuerzo frontal	-	-	-	-	-	1	1	-	-	-	
	Q411304	Remache avibulb Ø 4,8	-	-	-	-	-	4	4	-	-	-	
22	X142619	Apoyo panel frontal	1	1	1	1	-	1	1	1	1	-	
22	X282614	Apoyo panel frontal	-	-	-	-	1	-	-	-	-	1	
	Q302022	Arandela plana Ø16xØ6x1,2	2	2	2	2	2	2	2	2	2	2	
	Q262040	Arandela muelle A.6	2	2	2	2	2	2	2	2	2	2	
	Q012041	Tornillo exagonal M.6x10	2	2	2	2	2	2	2	2	2	2	
23	X140117	Panel superior armazón	1	1	1	1	-	1	1	1	1	-	
23	X280108	Panel superior armazón	-	-	-	-	1	-	-	-	-	1	
24	X172601	Listón soporte patas	2	2	2	2	-	2	2	2	2	-	
24	X582652	Listón soporte patas	-	-	-	-	2	-	-	-	-	2	
25	X140116	Poste anterior	2	2	2	2	2	2	2	2	2	2	
26	X140120	Liston transversal	2	2	2	2	2	2	2	2	2	2	
27	X142617	Refuerzo lateral	4	4	4	4	4	4	4	4	4	4	
28	X140127	Apoyo cuba izquierdo	1	1	1	1	1	1	1	1	1	1	
29	X260150	Pata regulable	4	4	4	4	4	4	4	4	4	4	
30	Q411304	Remache avibulb Ø 4,8	16	16	16	16	16	16	16	16	16	16	
31	X152813	Refuerzo inferior paneles	2	2	2	2	2	2	2	2	2	2	
	Q262040	Arandela muelle A.6	2	2	2	2	2	2	2	2	2	2	
	Q012042	Tornillo exagonal M.6x15	2	2	2	2	2	2	2	2	2	2	
	Q221342	Remache exagonal M.5	4	4	4	4	4	4	4	4	4	4	
	Q262030	Arandela muelle A.5	4	4	4	4	4	4	4	4	4	4	
	Q012032	Tornillo exagonal M.5x15	4	4	4	4	4	4	4	4	4	4	
32	X140123	Poste posterior izquierdo	1	1	-	-	-	1	1	-	-	-	
32	X340102	Poste posterior izquierdo	-	-	1	1	1	-	-	1	1	1	
33	X152621	Aislante panel lateral	2	2	2	2	2	-	-	-	-	-	
	Q419005	Remache tubular Ø 4x8	8	8	8	8	8	-	-	-	-	-	
34	Q411304	Remache avibulb Ø 4,8	8	8	8	8	8	8	8	8	8	8	
35	Q411302	Remache monobolt Ø 6,35	20	20	20	20	20	20	20	20	20	20	

<b>MOD.</b>	<b>SBG9-10</b> <b>SBG9-15</b>		<b>SBE9-10</b> <b>SBE9-15</b>		<b>ZONA</b>	<b>DESPIECE ARMAZON, CHIMENEA Y TAPA</b>					<b>PLANO</b>	<b>C-652</b>
	<b>Versiónes: I, M, S.</b>											

N°	CODIGO	DENOMINACION	SBG	SBG	SBG	SBG	SBG	SBE	SBE	SBE	SBE	SBE	NOTAS
			9-10	9-10 I	9-10 M	9-10 IM	9-15 IM	9-10	9-10 I	9-10 M	9-10 IM	9-15 IM	
36	X140106	Refuerzo posterior	1	1	-	-	-	1	1	-	-	-	
	Q411304	Remache avibulb Ø4,8	4	4	-	-	-	4	4	-	-	-	
36	X402600	Refuerzo posterior	-	-	1	1	-	-	-	1	1	-	
36	X280103	Refuerzo posterior	-	-	-	-	1	-	-	-	-	1	
	Q411302	Remache monobolt Ø 6,35	-	-	4	4	6	-	-	4	4	6	
37	X262613	Recogeaguas	1	1	1	1	1	1	1	1	1	1	
	Q419005	Remache tubular Ø 4x8	2	2	2	2	2	2	2	2	2	2	
38	X152616	Cierre anterior chimenea	1	1	1	1	-	-	-	-	-	-	
38	X282616	Cierre anterior chimenea	-	-	-	-	1	-	-	-	-	-	
	Q221342	Remache exagonal M.5	3	3	3	3	3	-	-	-	-	-	
	Q012031	Tornillo exagonal M.5x10	3	3	3	3	3	-	-	-	-	-	
	Q221342	Remache exagonal M.5	2	2	2	2	2	-	-	-	-	-	
39	X152653	Cierre posterior de chimenea	1	1	1	1	-	-	-	-	-	-	
39	X282652	Cierre posterior de chimenea	-	-	-	-	1	-	-	-	-	-	
40	X152628	Cierre lateral chimenea izdo.	1	1	1	1	-	-	-	-	-	-	
40	X282609	Cierre lateral chimenea izdo.	-	-	-	-	1	-	-	-	-	-	
s/n	X152627	Cierre lateral chimenea dcho.	1	1	1	1	-	-	-	-	-	-	
s/n	X282608	Cierre lateral chimenea dcho.	-	-	-	-	1	-	-	-	-	-	
41	X152608	Sujeción de chimenea	2	2	2	2	2	-	-	-	-	-	
	Q221343	Remache exagonal M.6	8	8	8	8	8	-	-	-	-	-	
	Q302022	Arandela plana Ø16xØ6x1,2	8	8	8	8	8	-	-	-	-	-	
	Q012042	Tornillo exagonal M.6x15	8	8	8	8	8	-	-	-	-	-	
42	X282607	Distanciador de chimenea	-	-	-	-	1	-	-	-	-	-	
43	R202607	Escuadra	2	2	2	2	2	-	-	-	-	-	
44	X152650	Trasera chimenea	1	1	1	1	-	-	-	-	-	-	
44	X282651	Trasera chimenea	-	-	-	-	1	-	-	-	-	-	
45	X152651	Delantera chimenea	1	1	1	1	-	-	-	-	-	-	
45	X282650	Delantera chimenea	-	-	-	-	1	-	-	-	-	-	
46	X152652	Cierre lateral de chimenea	2	2	2	2	2	-	-	-	-	-	
	Q419005	Remache tubular Ø4x8	33	33	33	33	38	-	-	-	-	-	

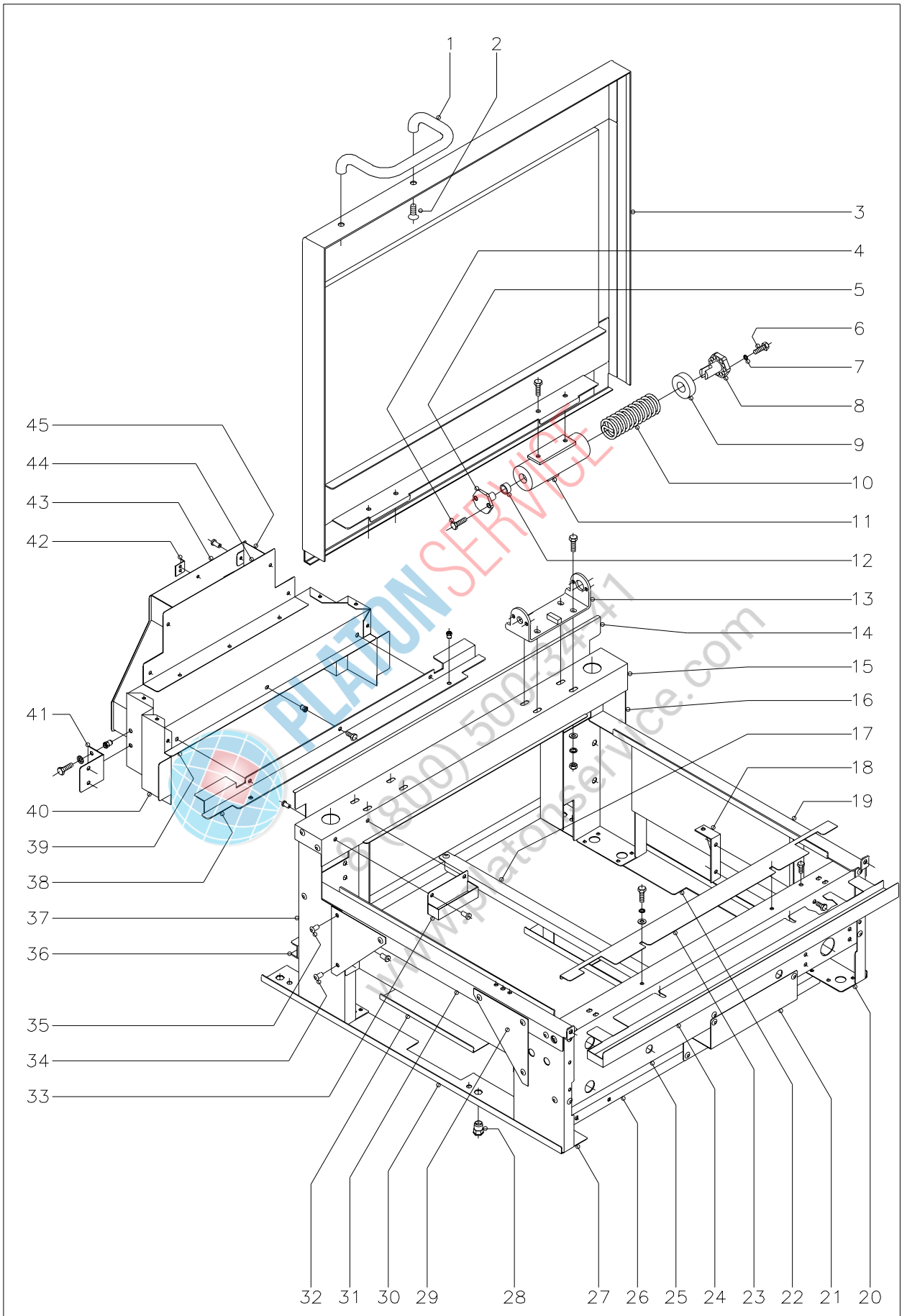

N plano C-653	Firma 	Fecha 1-99	Aparato SUSPENDIDA SARTEN BASCULANTE 900	Lamina 5	Fagor Industrial S.Coop. <b>FAGOR</b> Date
------------------	--	---------------	--	-------------	---

<b>MOD.</b>	<b>SBG9-10</b> <b>SBE9-10</b> <b>SBG9-15</b> <b>SBE9-15</b>  <b>Versiónes: I, M, S.</b>	<b>ZONA</b>	<b>DESPIECE ARMAZON,</b> <b>CHIMENEA Y TAPA</b>	<b>PLANO</b>	<b>C-653</b>
-------------	--	-------------	--	--------------	--------------

N°	CODIGO	DENOMINACION	SBG	SBG	SBE	SBE							NOTAS
			9-10 S	9-10 IS	9-10 S	9-10 IS							
1	S036123	Asa de tapa	1	1	1	1							
2	Q062036	Tornillo avellanado M.8x20	2	2	2	2							
3	X152823	Tapa	1	1	1	1							
4	Q012041	Tornillo exagonal M.6x10	4	4	4	4							
5	S116119	Giro de asa	2	2	2	2							
6	Q012042	Tornillo exagonal M.6x15	4	4	4	4							
7	Q262040	Arandela muelle A.6	4	4	4	4							
8	S116120	Tensor resorte	2	2	2	2							
9	S116118	Casquillo	2	2	2	2							
10	S116121	Resorte tapa	2	2	2	2							
11	X156101	Bisagra	2	2	2	2							
	Q012051	Tornillo exagonal M.8x10	4	4	4	4							
12	S116126	Cojinete cilíndrico	2	2	2	2							
13	X286102	Soporte de bisagra	2	2	2	2							
	Q012053	Tornillo exagonal M.8x20	8	8	8	8							
	Q232050	Arandela plana A.8	8	8	8	8							
	Q262050	Arandela muelle A.8	8	8	8	8							
	Q162050	Tuerca exagonal M.8	8	8	8	8							
14	X152638	Listón posterior	1	1	1	1							
	Q419005	Remache tubular Ø4x8	5	5	5	5							
15	X140125	Cubierta puente	1	1	1	1							
16	X240114	Poste posterior derecho	1	1	1	1							
17	X140128	Listón refuerzo	-	-	1	1							
	Q411304	Remache avibulb Ø4,8	-	-	2	2							
18	X142618	Refuerzo sarten	2	2	2	2							
	Q012042	Tornillo exagonal M.6x15	6	6	6	6							
19	X140126	Apoyo cuba derecho	1	1	1	1							
20	X240113	Poste anterior	1	1	1	1							
21	X250116	Refuerzo frontal	-	-	1	1							
	Q411304	Remache avibulb Ø 4,8	-	-	4	4							
22	X240111	Listón transversal derecho	1	1	1	1							

<b>MOD.</b>	<b>SBG9-10</b>	<b>SBE9-10</b>	<b>ZONA</b>	<b>DESPIECE ARMAZON, CHIMENEA Y TAPA</b>	<b>PLANO</b>	<b>C-653</b>
	<b>SBG9-15</b>	<b>SBE9-15</b>				
	<b>Versiónes: I, M, S.</b>					

Nº	CODIGO	DENOMINACION	SBG	SBG	SBE	SBE							NOTAS
			9-10 S	9-10 I S	9-10 S	9-10 IS							
23	X152645	Freno de humos	1	1	-	-							
24	X142619	Apoyo panel frontal	1	1	1	1							
	Q302022	Arandela plana Ø16xØ6x1,2	2	2	2	2							
	Q262040	Arandela muelle A.6	2	2	2	2							
	Q012041	Tornillo exagonal M.6x10	2	2	2	2							
25	X140117	Panel superior armazon	1	1	1	1							
26	X240110	Liston frontal	1	1	1	1							
27	X240113	Poste anterior	1	1	1	1							
28	R121345	Remache exagonal M.10	2	2	2	2							
29	X142617	Refuerzo lateral	4	4	4	4							
30	X240112	Liston transversal izquierdo	1	1	1	1							
31	X140127	Apoyo cuba izquierdo	1	1	1	1							
32	X152621	Aislante panel lateral	2	2	-	-							
	Q419005	Remache tubular Ø4x8	8	8	-	-							
33	X262613	Recogeaguas	1	1	1	1							
	Q419005	Remache tubular Ø4x8	2	2	2	2							
34	Q411304	Remache avibulb Ø4,8	8	8	8	8							
35	Q411302	Remache monobolt Ø6,35	20	20	20	20							
36	X140106	Refuerzo posterior	1	1	1	1							
	Q411304	Remache avibulb Ø4,8	4	4	4	4							
37	X240115	Poste posterior izquierdo	1	1	1	1							
38	X152616	Cierre anterior chimenea	1	1	-	-							
	Q221342	Remache exagonal M.5	3	3	-	-							
	Q012031	Tornillo exagonal M.5x10	3	3	-	-							
	Q221342	Remache exagonal M.5	2	2	-	-							
39	X152653	Cierre posterior de chimenea	1	1	-	-							
40	X152628	Cierre lateral chimenea izdo.	1	1	-	-							
s/n	X152627	Cierre lateral chimenea dcho.	1	1	-	-							
41	X152608	Sujección de chimenea	2	2	-	-							
	Q221343	Remache exagonal M.6	8	8	-	-							
	Q302022	Arandela plana Ø16xØ6x1,2	8	8	-	-							



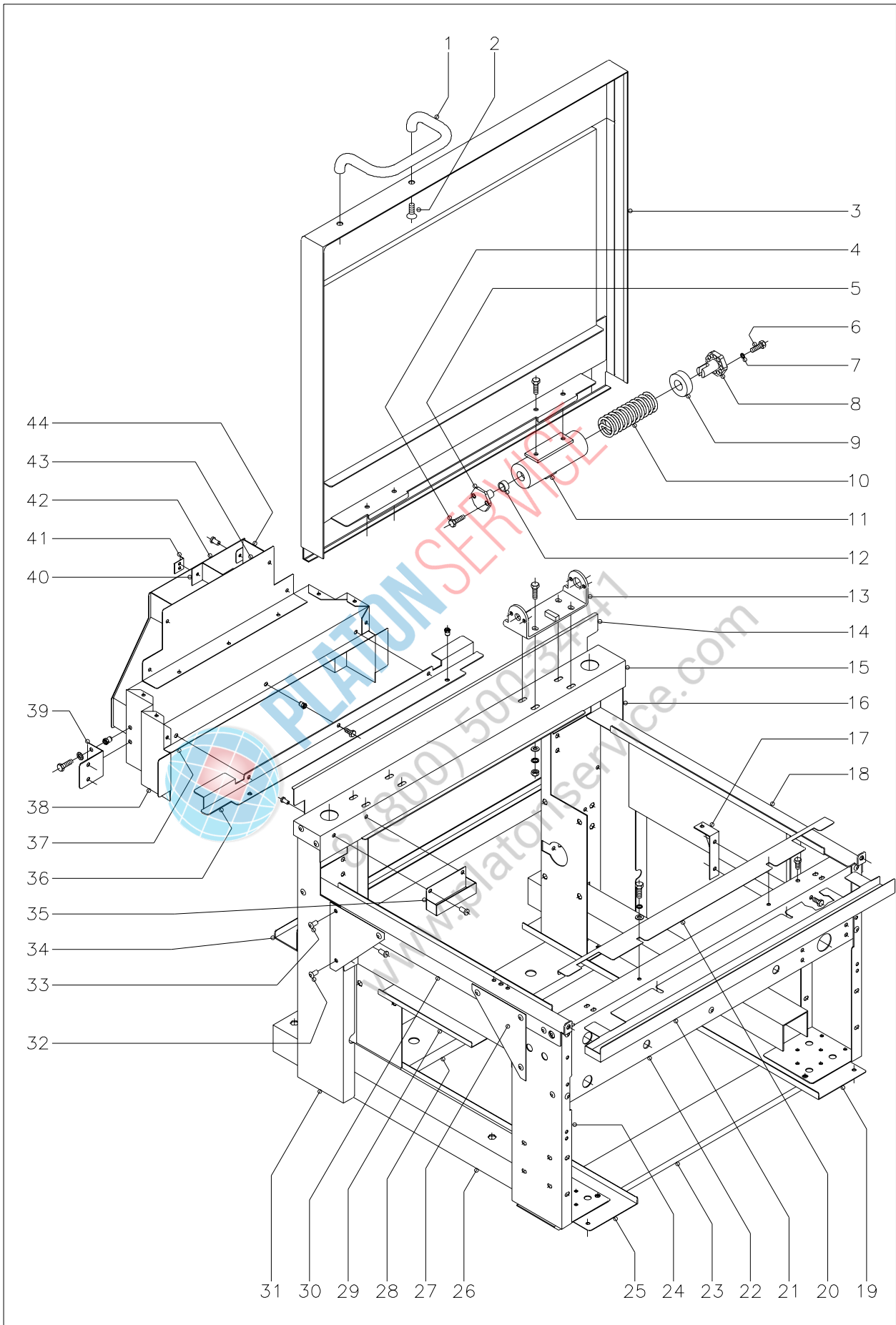

N plano C-654	Firma 	Fecha 1-99	Aparato SUSPENDIDA MOTORIZADA SARTEN BASCULANTE 900	Lamina 6	Fagor Industrial S.Coop. <b>FAGOR</b> Ocate
------------------	--	---------------	---	-------------	--



MOD.

SBG9-10  
SBG9-15SBE9-10  
SBE9-15

Versiones: I, M, S.

ZONA

DESPIECE ARMAZON,  
CHIMENEA Y TAPA

PLANO

C-654

N°	CODIGO	DENOMINACION	SBG	SBG	SBG	SBE	SBE	SBE					NOTAS
			9-10 MS	9-10 IMS	9-15 IMS	9-10 MS	9-10 IMS	9-15 IMS					
1	S036123	Asa de tapa	1	1	1	1	1	1					
2	Q062036	Tornillo avellanado M.8x20	2	2	2	2	2	2					
3	X152823	Tapa	1	1	-	1	1	-					
3	X282812	Tapa	-	-	1	-	-	1					
4	Q012041	Tornillo exagonal M.6x10	4	4	4	4	4	4					
5	S116119	Giro de asa	2	2	2	2	2	2					
6	Q012042	Tornillo exagonal M.6x15	4	4	4	4	4	4					
7	Q262040	Arandela muelle A.6	4	4	4	4	4	4					
8	S116120	Tensor resorte	2	2	2	2	2	2					
9	S116118	Casquillo	2	2	2	2	2	2					
10	S116121	Resorte tapa	2	2	2	2	2	2					
11	X156101	Bisagra	2	2	2	2	2	2					
	Q012051	Tornillo exagonal M.8x10	4	4	4	4	4	4					
12	S116126	Cojinete cilíndrico	2	2	2	2	2	2					
13	X286102	Soporte de bisagra	2	2	2	2	2	2					
	Q012053	Tornillo exagonal M.8x20	8	8	8	8	8	8					
	Q232050	Arandela plana A.8	8	8	8	8	8	8					
	Q262050	Arandela muelle A.8	8	8	8	8	8	8					
	Q162050	Tuerca exagonal M.8	8	8	8	8	8	8					
14	X152638	Listón posterior	1	1	-	1	1	-					
14	X282613	Listón posterior	-	-	1	-	-	1					
	Q419005	Remache tubular Ø4x8	5	5	5	5	5	5					
15	X140125	Cubierta puente	1	1	-	1	1	-					
15	X280104	Cubierta puente	-	-	1	-	-	1					
16	X410104	Poste posterior derecho	1	1	1	1	1	1					
17	X140126	Apoyo cuba derecho	1	1	1	1	1	1					
18	X142618	Refuerzo sarten	2	2	2	2	2	2					
	Q012042	Tornillo exagonal M.6x15	6	6	6	6	6	6					
19	X410102	Listón transversal derecho	1	1	1	1	1	1					
20	X152645	Freno de humos	1	1	-	-	-	-					
20	X282617	Freno de humos	-	-	1	-	-	-					

<b>MOD.</b>	<b>SBG9-10</b>	<b>SBE9-10</b>	<b>ZONA</b>	<b>DESPIECE ARMAZON, CHIMENEA Y TAPA</b>	<b>PLANO</b>	<b>C-654</b>
	<b>SBG9-15</b>	<b>SBE9-15</b>				
	<b>Versiónes: I, M, S.</b>					

N°	CODIGO	DENOMINACION	SBG	SBG	SBG	SBE	SBE	SBE					NOTAS
			9-10 MS	9-10 IMS	9-15 IMS	9-10 MS	9-10 IMS	9-15 IMS					
21	X142619	Apoyo panel frontal	1	1	-	1	1	-					
21	X282614	Apoyo panel frontal	-	-	1	-	-	1					
	Q302022	Arandela plana Ø16xØ6x1,2	2	2	2	2	2	2					
	Q262040	Arandela muelle A.6	2	2	2	2	2	2					
	Q012041	Tornillo exagonal M.6x10	2	2	2	2	2	2					
22	X140117	Panel superior armazon	1	1	-	1	1	-					
22	X280108	Panel superior armazon	-	-	1	-	-	1					
23	X172601	Listón soporte patas	1	1	-	1	1	-					
23	U582652	Listón soporte patas	-	-	1	-	-	1					
24	X140116	Poste anterior	2	2	2	2	2	2					
25	X410103	Liston transversal izquierdo	1	1	1	1	1	1					
26	X410106	Apoyo armazon	2	2	2	2	2	2					
27	X142617	Refuerzo lateral	4	4	4	4	4	4					
28	X452600	Listón longitudinal posterior	1	1	-	1	1	-					
28	X410101	Listón longitudinal posterior	-	-	1	-	-	1					
29	X152621	Aislante panel lateral	2	2	2	-	-	-					
	Q419005	Remache tubular Ø4,8	8	8	8	-	-	-					
30	X140127	Apoyo cuba izquierdo	1	1	1	1	1	1					
31	X410105	Poste posterior izquierdo	1	1	1	1	1	1					
32	Q411304	Remache avibulb Ø 4,8	8	8	8	8	8	8					
33	Q411302	Remache monobolt Ø 6,35	20	20	20	20	20	20					
34	X402600	Refuerzo posterior	1	1	1	1	1	1					
35	X262613	Recogeaguas	1	1	1	1	1	1					
	Q419005	Remache tubular Ø4,8	2	2	2	2	2	2					
36	X152616	Cierre anterior chimenea	1	1	-	-	-	-					
36	X282616	Cierre anterior chimenea	-	-	1	-	-	-					
	Q221342	Remache exagonal M.5	3	3	3	-	-	-					
	Q012031	Tornillo exagonal M.5x10	3	3	3	-	-	-					
	Q221342	Remache exagonal M.5	2	2	2	-	-	-					
37	X152653	Cierre posterior de chimenea	1	1	-	-	-	-					
37	X282652	Cierre posterior de chimenea	-	-	1	-	-	-					
38	X152628	Cierre lateral chimenea izdo.	1	1	-	-	-	-					



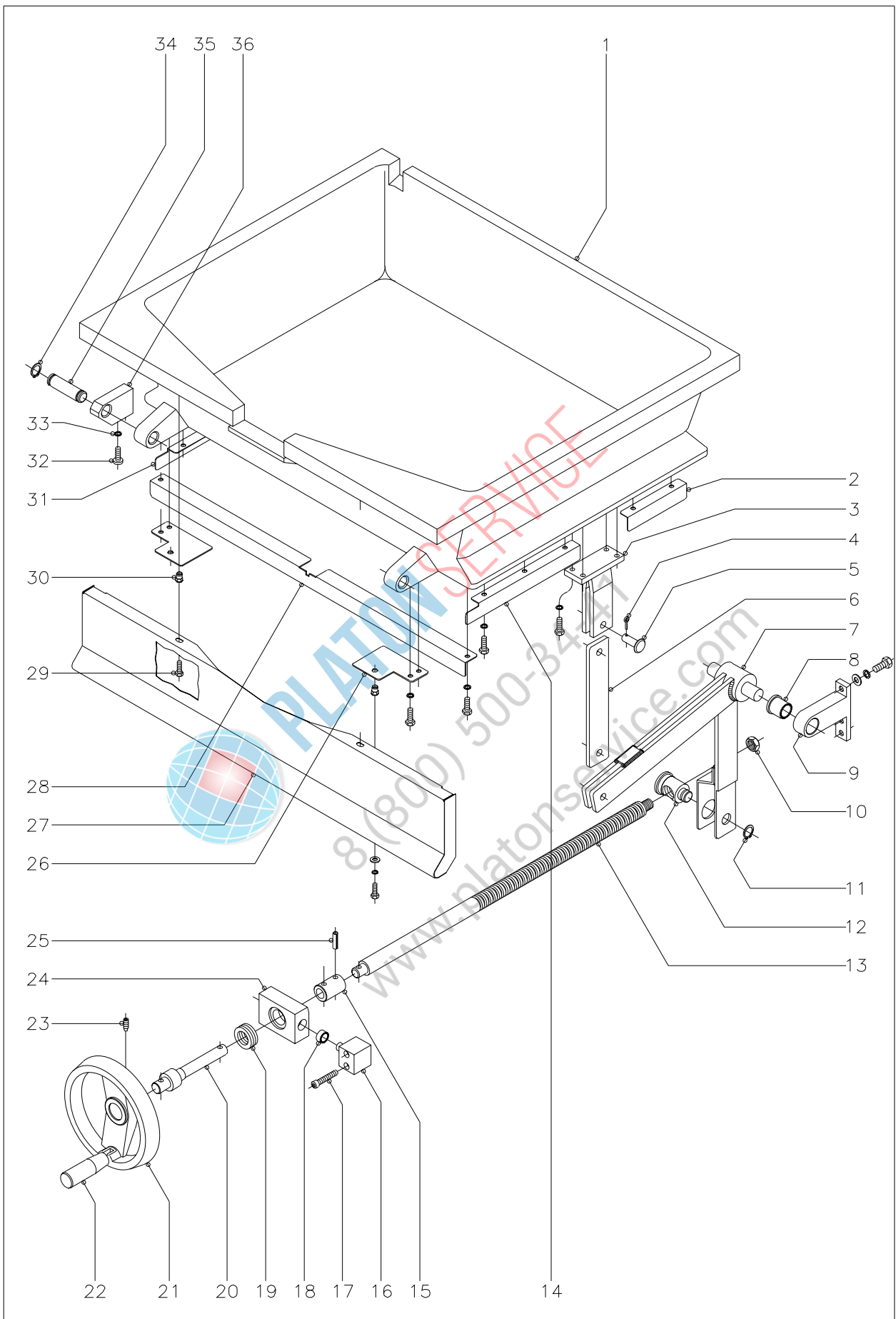

N plano C-655	Firma 	Fecha 1-99	Aparato SARTEN BASCULANTE 900	Lámina 7	Fagor Industrial S.Coop. <b>FAGOR</b> Olate
------------------	--	---------------	----------------------------------	-------------	--

<b>MOD.</b>	<b>SBG9-10</b> <b>SBE9-10</b> <b>SBG9-15</b> <b>SBE9-15</b>		<b>ZONA</b>	<b>DESPIECE CUBA ELEVACION</b> <b>CON VOLANTE</b>		<b>PLANO</b>	<b>C-655</b>
	<b>Versiónes: I, M, S.</b>						

Nº	CODIGO	DENOMINACION	SBG 9-10	SBG 9-10 I	SBG 9-10 S	SBG 9-10 IS	SBE 9-10	SBE 9-10 I	SBE 9-10 S	SBE 9-10 IS			NOTAS
1	X156137	Cuba de fundición	1	-	1	-	-	-	-	-			
1	X156136	Cuba de inoxidable	-	1	-	1	-	-	-	-			
1	X146116	Cuba de fundición	-	-	-	-	1	-	1	-			
1	X146120	Cuba inoxidable	-	-	-	-	-	1	-	1			
2	X156132	Cierre lateral derecho corto	1	-	1	-	-	-	-	-			
	Q262040	Arandela grower A.6	2	-	2	-	-	-	-	-			
	Q012042	Tornillo exagonal M.6x15	2	-	2	-	-	-	-	-			
3	X156126	Horquilla de giro	1	-	1	-	1	-	1	-			
	Q262040	Arandela grower A.6	4	-	4	-	4	-	4	-			
	Q012042	Tornillo exagonal M.6x15	4	-	4	-	4	-	4	-			
4	Q352024	Pasador de aletas	2	2	2	2	2	2	2	2			
5	X156123	Bulón Ø 12	2	2	2	2	2	2	2	2			
6	X156124	Brazo	1	1	1	1	1	1	1	1			
7	X156112	Brazo elevador	1	1	1	1	1	1	1	1			
8	X109550	Cojinete	2	2	2	2	2	2	2	2			
9	X150108	Soporte giro	2	2	2	2	2	2	2	2			
	Q232060	Arandela plana A.10	4	4	4	4	4	4	4	4			
	Q261060	Arandela grower A.10	4	4	4	4	4	4	4	4			
	Q011364	Tornillo exagonal M.10x25	4	4	4	4	4	4	4	4			
10	Q222015	Tuerca exagonal 3/8"	1	1	1	1	1	1	1	1			
11	Q301020	Anillo seguridad Ø 20x1,2	1	1	1	1	1	1	1	1			
12	X126108	Tuerca de husillo	1	1	1	1	1	1	1	1			
13	X156111	Husillo	1	1	1	1	1	1	1	1			
14	X156131	Cierre lateral derecho	1	-	1	-	-	-	-	-			
	Q262040	Arandela grower A.6	3	-	3	-	-	-	-	-			
	Q012042	Tornillo exagonal M.6x15	3	-	3	-	-	-	-	-			
15	X156115	Casquillo	1	1	1	1	1	1	1	1			
16	X156113	Pivote de giro	2	2	2	2	2	2	2	2			
17	Q052046	Tornillo allen M.6x40	4	4	4	4	4	4	4	4			
18	S116126	Cojinete cilíndrico	2	2	2	2	2	2	2	2			
19	X156125	Rodamiento	1	1	1	1	1	1	1	1			

<b>MOD.</b>	<b>SBG9-10</b>	<b>SBE9-10</b>	<b>ZONA</b>	<b>DESPIECE CUBA ELEVACION CON VOLANTE</b>	<b>PLANO</b>	<b>C-655</b>
	<b>SBG9-15</b>	<b>SBE9-15</b>				
	<b>Versiónes: I, M, S.</b>					

Nº	CODIGO	DENOMINACION	SBG 9-10	SBG 9-10 I	SBG 9-10 S	SBG 9-10 IS	SBE 9-10	SBE 9-10 I	SBE 9-10 S	SBE 9-10 IS			NOTAS
20	X156116	Eje volante	1	1	1	1	1	1	1	1			
21	X156139	Volante con mango	1	1	1	1	1	1	1	1			
22	X156135	Mango abatible inox.	1	1	1	1	1	1	1	1			
23	Q131552	Varilla roscada allen M.8x15	2	2	2	2	2	2	2	2			
24	X156114	Soporte rodamiento	1	1	1	1	1	1	1	1			
25	Q371027	Manguito Ø8x30	2	2	2	2	2	2	2	2			
26	X156138	Amarre portamandos	2	-	2	-	2	-	2	-			
	Q262040	Arandela grower A.6	4	-	4	-	4	-	4	-			
	Q012042	Tornillo exagonal M.6x15	4	-	4	-	4	-	4	-			
	Q221343	Remache exagonal M. 6	2	2	2	2	2	2	2	2			
27	X152830	Panel portamandos	1	-	1	-	1	-	1	-			
27	X152833	Panel portamandos	-	1	-	1	-	1	-	1			
	Q302022	Arandela plana Ø16xØ6x1,2	2	2	2	2	2	2	2	2			
	Q262040	Arandela grower A.6	2	2	2	2	2	2	2	2			
	Q012042	Tornillo exagonal M.6x15	2	2	2	2	2	2	2	2			
28	X156128	Cierre de humos	1	-	1	-	-	-	-	-			
	Q262040	Arandela grower A.6	2	-	2	-	-	-	-	-			
	Q012042	Tornillo exagonal M.6x15	2	-	2	-	-	-	-	-			
29	Q012042	Tornillo exagonal M.6x15	2	2	2	2	2	2	2	2			
30	Q221343	Remache exagonal M. 6	-	2	-	2	-	2	-	2			
31	X156133	Cierre lateral izquierdo	1	-	1	-	-	-	-	-			
	Q262040	Arandela grower A.6	3	-	3	-	-	-	-	-			
	Q012042	Tornillo exagonal M.6x15	3	-	3	-	-	-	-	-			
32	Q052053	Tornillo allen M.8x20	4	4	4	4	4	4	4	4			
33	Q262050	Arandela grower A.8	4	4	4	4	4	4	4	4			
34	Q301020	Anillo de seguridad Ø 20x1,2	4	4	4	4	4	4	4	4			
35	X109511	Bulón	2	2	2	2	2	2	2	2			
36	X140110	Soporte giro cuba	2	2	2	2	2	2	2	2			

N plano  
C-656

Firma

Fecha  
1-99

Aparato  
SARTEN BASCULANTE 900

Laminas  
8

Fagor Industrial S.Coop.  
O.cite

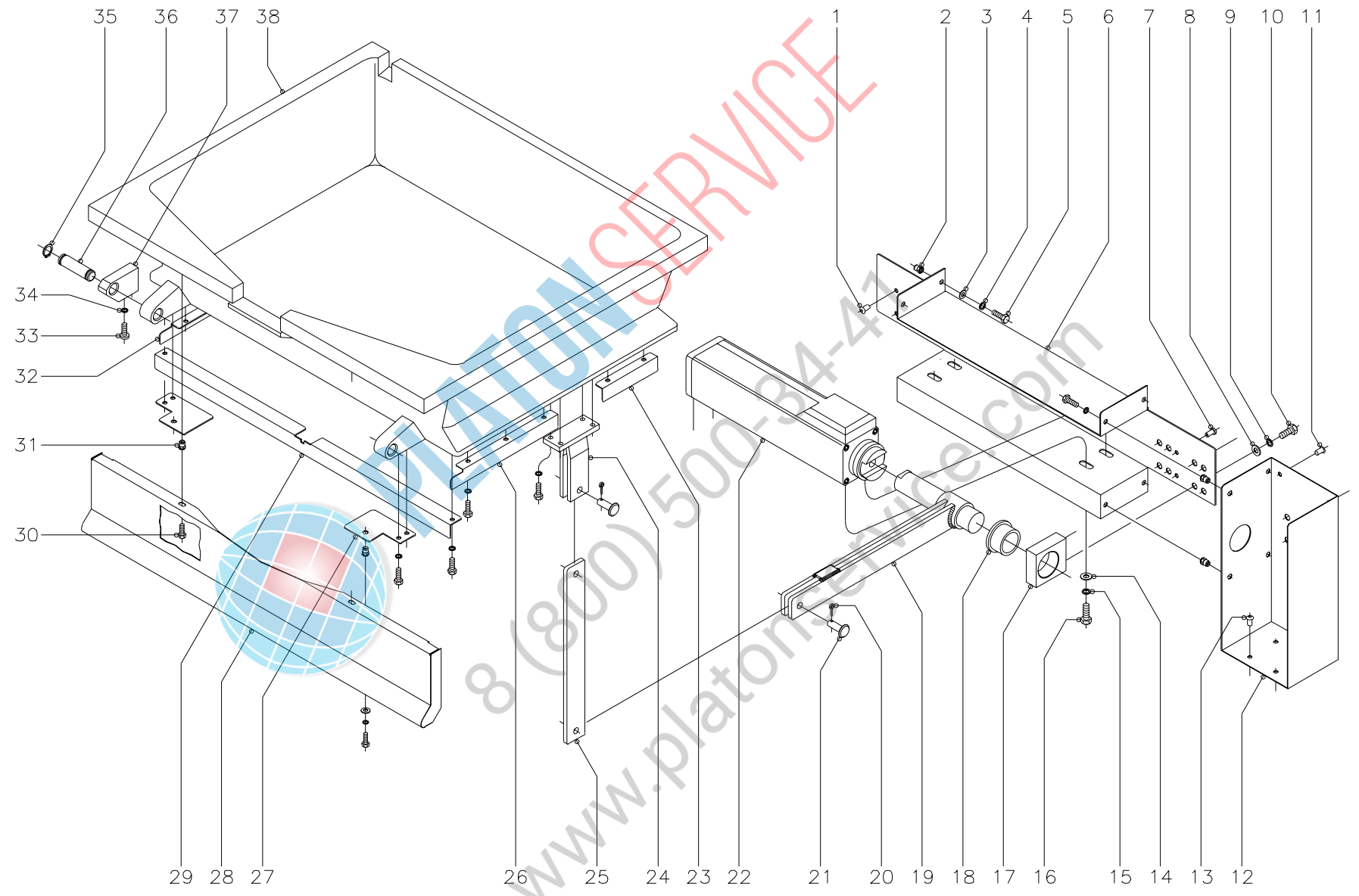

MOD.

SBG9-10  
SBG9-15SBE9-10  
SBE9-15

Versiones: I, M, S.

ZONA

DESPIECE CUBA CON  
ELEVACION MOTORIZADA

PLANO

C-656

Nº	CODIGO	DENOMINACION	SBG	SBG	SBG	SBE	SBE	SBE					NOTAS
			9-10 M 9-10 MS	9-10 IM 9-10 IMS	9-15 IM 9-15 IMS	9-10 M 9-10 MS	9-10 IM 9-10 IMS	9-15 IM 9-15 IMS					
1	Q411302	Remache monobolt Ø 6,35	4	4	4	4	4	4					
2	Q221344	Remache exagonal M.8	8	8	8	8	8	8					
3	Q232050	Arandela plana A.8	8	8	8	8	8	8					
4	Q262050	Arandela grower A.8	8	8	8	8	8	8					
5	Q012053	Tornillo exagonal M.8x20	8	8	8	8	8	8					
6	X340104	Soporte motor	1	1	1	1	1	-					
6	X422604	Soporte motor	-	-	-	-	-	1					
7	Q411304	Remache avibulb	2	2	2	2	2	2					
8	Q232060	Arandela plana A.10	4	4	4	4	4	4					
9	Q261060	Arandela muelle A.10	4	4	4	4	4	4					
10	Q012063	Tornillo exagonal M.10x20	4	4	4	4	4	4					
11	Q411302	Remache monobolt Ø 6,35	-	-	2	-	-	2					
12	X280105	Poste posterior central	-	-	1	-	-	1					
13	Q411302	Remache monobolt Ø 6,35	-	-	4	-	-	4					
14	Q232060	Arandela plana A.10	4	4	4	4	4	4					
15	Q261060	Arandela muelle A.10	4	4	4	4	4	4					
16	Q012063	Tornillo exagonal M.10x20	4	4	4	4	4	4					
17	X346103	Soporte giro brazo	2	2	2	2	2	2					
18	X346102	Cojinete	2	2	2	2	2	2					
19	X346100	Brazo elevador	1	1	1	1	1	1					
20	Q352024	Pasador de aletas	2	2	2	2	2	2					
21	X156123	Bulón Ø 12	2	2	2	2	2	2					
22	X343000	Motorreductor de elevación	1	1	1	1	1	1					
23	X156132	Cierre lateral derecho corto	1	-	-	-	-	-					
	Q262040	Arandela grower A.6	2	-	-	-	-	-					
	Q012042	Tornillo exagonal M.6x15	2	-	-	-	-	-					
24	X156126	Horquilla de giro	1	-	-	1	-	-					
	Q262040	Arandela grower A.6	4	-	-	4	-	-					
	Q012042	Tornillo exagonal M.6x15	4	-	-	4	-	-					
25	X346101	Brazo	1	1	1	1	1	1					
26	X156131	Cierre lateral dereho	1	-	-	-	-	-					



<b>MOD.</b>	<b>SBG9-10</b>	<b>SBE9-10</b>	<b>ZONA</b>	<b>DESPIECE CUBA CON ELEVACION MOTORIZADA</b>	<b>PLANO</b>	<b>C-656</b>
	<b>SBG9-15</b>	<b>SBE9-15</b>				
	<b>Versiónes: I, M, S.</b>					

N°	CODIGO	DENOMINACION	SBG	SBG	SBG	SBE	SBE	SBE					NOTAS
			9-10 M 9-10 MS	9-10 MI 9-10 IMS	9-15 IM 9-15 IMS	9-10 M 9-10 MS	9-10 IM 9-10 IMS	9-15 IM 9-15 IMS					
	Q262040	Arandela grower A.6	3	-	-	-	-	-					
	Q012042	Tornillo exagonal M.6x15	3	-	-	-	-	-					
27	X156138	Amarre portamandos	2	-	-	2	-	-					
	Q262040	Arandela grower A.6	4	-	-	4	-	-					
	Q012042	Tornillo exagonal M.6x15	4	-	-	4	-	-					
	Q221343	Remache exagonal M.6	2	-	-	2	-	-					
28	X152830	Panel portamandos	1	-	-	1	-	-					
28	X152833	Panel portamandos	-	1	-	-	1	-					
28	X282815	Panel portamandos	-	-	1	-	-	1					
	Q302022	Arandela plana Ø16xØ6x1,2	2	2	2	2	2	2					
	Q262040	Arandela grower A.6	2	2	2	2	2	2					
	Q012042	Tornillo exagonal M.6x15	2	2	2	2	2	2					
29	X156128	Cierre de humos	1	-	-	-	-	-					
	Q262040	Arandela grower A.6	2	-	-	-	-	-					
	Q012042	Tornillo exagonal M.6x15	2	-	-	-	-	-					
30	Q012042	Tornillo exagonal M.6x15	2	2	2	2	2	2					
31	Q221343	Remache exagonal M.6	-	2	2	-	2	2					
32	X156133	Cierre lateral izquierdo	1	-	-	-	-	-					
	Q262040	Arandela grower A.6	3	-	-	-	-	-					
	Q012042	Tornillo exagonal M.6x15	3	-	-	-	-	-					
33	Q052053	Tornillo allen M.8x20	4	4	4	4	4	4					
34	Q262050	Arandela grower A.8	4	4	4	4	4	4					
35	Q301020	Anillo de seguridad Ø 20x1,2	4	4	4	4	4	4					
36	X109511	Bulón	2	2	2	2	2	2					
37	X140110	Soporte giro cuba	2	2	2	2	2	2					
38	X156137	Cuba de fundición g.10	1	-	-	-	-	-					
38	X156136	Cuba inoxidable g.10	-	1	-	-	-	-					
38	X286103	Cuba inoxidable g.15	-	-	1	-	-	-					
38	X146116	Cuba de fundición e.10	-	-	-	1	-	-					
38	X146115	Cuba inoxidable g.10	-	-	-	-	1	-					
38	X426100	Cuba inoxidable g.15	-	-	-	-	-	1					

<b>MOD.</b>	<b>SBG9-10</b> <b>SBE9-10</b> <b>SBG9-15</b> <b>SBE9-15</b>		<b>ZONA</b>	<b>DESPIECE PARTE FUNCIONAL</b> <b>GAS</b>		<b>PLANO</b>	<b>C-657</b>
	<b>Versiónes: I, M, S.</b>						

Nº	CODIGO	DENOMINACION	SBG 9-10 9-10 I	SBG 9-10 M 9-10 IM	SBG 9-15 IM	SBG 9-10 S 9-10 IS	SBG 9-10 MS 9-10 IMS	SBG 9-15 IMS						NOTAS
1	X155720	Deflector largo	4	4	-	4	4	-						
1	X285707	Deflector largo	-	-	7	-	-	7						
1	X155721	Deflector corto	1	1	-	1	1	-						
1	X285708	Deflector corto	-	-	1	-	-	1						
2	Q419005	Remache tubular Ø 4x8	10	10	16	10	10	16						
3	X155700	Quemador	1	1	-	1	1	-						
3	X285700	Quemador	-	-	1	-	-	1						
	Q152004	Tornillo aplastado M.5x13	2	2	2	2	2	2						
	Q221342	Remache exagonal M.5	2	2	2	2	2	2						
4	U325707	Regulador de aire	2	2	3	2	2	3						
	Q012031	Tornillo exagonal M.5x10	2	2	3	2	2	3						
5	U052401	Tobera Ø 1,45 (G.L.P.)	2	2	3	2	2	3						
5	U262400	Tobera Ø 2,15 (G. N.)	2	2	3	2	2	3						
5	X102403	Tobera Ø 4,58 (G. V.)	2	2	3	2	2	3						
6	Q223019	Tuerca exagonal 3/8"	2	2	3	2	2	3						
7	Q301323	Arandela Ø25xØ17x6	2	2	3	2	2	3						
8	X155015	Conducción a quemador	1	1	-	-	1	-						
8	X245012	Conducción a quemador	-	-	-	1	-	-						
8	X285010	Conducción a quemador	-	-	1	-	-	1						
9	Q153002	Tornillo tapón	2	2	3	2	2	3						
10	X205028	Bicono Ø 6	1	1	1	1	1	1						
11	U195009	Manguíto empalme	1	1	1	1	1	1						
12	U562130	Termopar L=850 mm.	1	1	1	1	1	1						
13	Q345004	Tubo piloto	1	1	-	1	1	-						
13	Q285006	Tubo piloto	-	-	1	-	-	1						
14	X153005	Manguito 1/2" SIT	1	1	1	1	1	1						
		Junta tórica	1	1	1	1	1	1						
		Tornillo de amarre	4	4	4	4	4	4						
15	X262100	Alargadera pulsador	1	1	1	-	1	1						
16	U134321	Tornillo alomado M.4x15	1	1	1	1	1	1						
17	R275027	Cableado electrosit	1	1	1	1	1	1						

<b>MOD.</b>	<b>SBG9-10</b> <b>SBE9-10</b> <b>SBG9-15</b> <b>SBE9-15</b>		<b>ZONA</b>	<b>DESPIECE PARTE FUNCIONAL</b> <b>GAS</b>	<b>PLANO</b>	<b>C-657</b>
	<b>Versiones: I, M, S.</b>					

Nº	CODIGO	DENOMINACION	SBG 9-10 9-10 I	SBG 9-10 M 9-10 IM	SBG 9-15 IM	SBG 9-10 S 9-10 IS	SBG 9-10MS 9-10 IMS	SBG 9-15IMS						NOTAS
18	X163000	Electroválvula 820 nova	1	1	1	1	1	1						
19	X153004	Codo 1/2" SIT	1	1	1	1	1	1						
		Junta tórica	1	1	1	1	1	1						
		Tornillo de amarre	4	4	4	4	4	4						
20	U725005	Codo de entrada gas	1	1	1	-	-	-						
21	U725006	Tuerca 3/4"	1	1	1	-	-	-						
22	Q300012	Arandela junta Ø18xØ13x1,5	1	1	1	-	-	-						
23	X162101	Racord 1/2"	2	2	2	2	2	2						
24	X012105	Bicono Ø 16	2	2	2	2	2	2						
25	X012104	Manguito para racord 1/2"	2	2	2	2	2	2						
26	X155017	Conducción de entrada	1	1	1	-	-	-						
26	X245010	Conducción de entrada	-	-	-	1	-	-						
26	X415000	Conducción de entrada	-	-	-	-	1	1						
27	X152635	Soporte válvula	1	1	1	-	1	1						
27	X242605	Soporte válvula	-	-	-	1	-	-						
	Q262030	Arandela grower A.5	2	2	2	2	2	2						Amarre a válvula
	Q012031	Tornillo exagonal M.5x10	2	2	2	2	2	2						Amarre a válvula
28	S112804	Embellecedor tubo de encendido	1	1	1	1	1	1						
29	Q306027	Arandela junta Ø33,8xØ27x1,5	1	1	1	1	1	1						
30	Q221324	Tuerca exagonal 3/4"	1	1	1	1	1	1						
31	R165011	Tubo de encendido	1	1	1	1	1	1						
	Q012031	Tornillo exagonal M.5x10	2	2	2	2	2	2						
32	X012101	Bujía de encendido	1	1	1	1	1	1						
33	Q012031	Tornillo exagonal M.5x10	2	2	3	2	2	3						
34	U134323	Racord c/bicono Ø 6	1	1	1	1	1	1						
35	U322118	Piloto completo	1	1	1	1	1	1						

<b>MOD.</b>	<b>SBG9-10</b> <b>SBE9-10</b> <b>SBG9-15</b> <b>SBE9-15</b>		<b>ZONA</b>	<b>DESPIECE PARTE FUNCIONAL</b> <b>ELECTRICA</b>	<b>PLANO</b>	<b>C-658</b>
	<b>Versiones: I, M, S.</b>					

Nº	CODIGO	DENOMINACION	SBG 9-10 9-10 I	SBG 9-10 M 9-10 IM	SBG 9-15 IM	SBG 9-10 S 9-10 IS	SBG 9-10 MS 9-10 IMS	SBG 9-15 IMS						NOTAS
1	Z203004	Piloto verde	1	1	1	1	1	1						
2	Z203005	Piloto ámbar	1	1	1	1	1	1						
3	X152110	Botón de mando Ø 6	1	1	1	1	1	1						
4	X152822	Panel frontal	1	-	-	-	-	-						
4	X342801	Panel frontal	-	1	-	-	-	-						
4	X282810	Panel frontal	-	-	1	-	-	-						
4	X242816	Panel frontal	-	-	-	1	-	-						
4	X342801	Panel frontal	-	-	-	-	1	-						
4	X282810	Panel frontal	-	-	-	-	-	1						
5	Q161450	Tuerca exagonal M.8	-	1	1	-	1	1						
6	X343001	Condensador 5 MF.	-	1	1	-	1	1						
7	Q162030	Tuerca exagonal M.5	-	1	1	-	1	1						
8	Q012031	Tornillo exagonal M.5x10	-	1	1	-	1	1						
9	X343004	Cubierta condensador	-	1	1	-	1	1						
10	X343002	Interruptor basculante	-	1	1	-	1	1						
11	X242601	Tapa frontal	1	1	1	1	1	1						
12	X163007	Conmutador acople termostato	1	1	1	1	1	1						
	Q151320	Tornillo alomado M.4x6	2	2	2	2	2	2						
13	X313001	"U" Soporte termostato	1	1	1	1	1	1						
14	X153000	Termostato 50-310°C	1	1	1	1	1	1						
15	X343015	Microrruptor	1	2	2	1	2	2						
16	Q222005	Tuerca exagonal M.10x0,75	1	2	2	1	2	2						
17	X153006	Soporte eje micro	1	2	2	1	2	2						
18	Z700603	Muelle	1	2	2	1	2	2						
19	Q221342	Remache exagonal M.5	2	4	4	2	4	4						
20	Q012031	Tornillo exagonal M.5x10	2	4	4	2	4	4						
21	X153007	Eje pulsador micro	1	2	2	1	2	2						
22	Q271033	Arandela de seguridad Ø 6	2	4	4	2	4	4						
23	X342600	Tapa caja regleta	1	1	1	-	1	1						
	Q302022	Arandela plana Ø16xØ6x1,2	2	2	2	-	2	2						
	Q012042	Tornillo exagonal M.6x15	2	2	2	-	2	2						



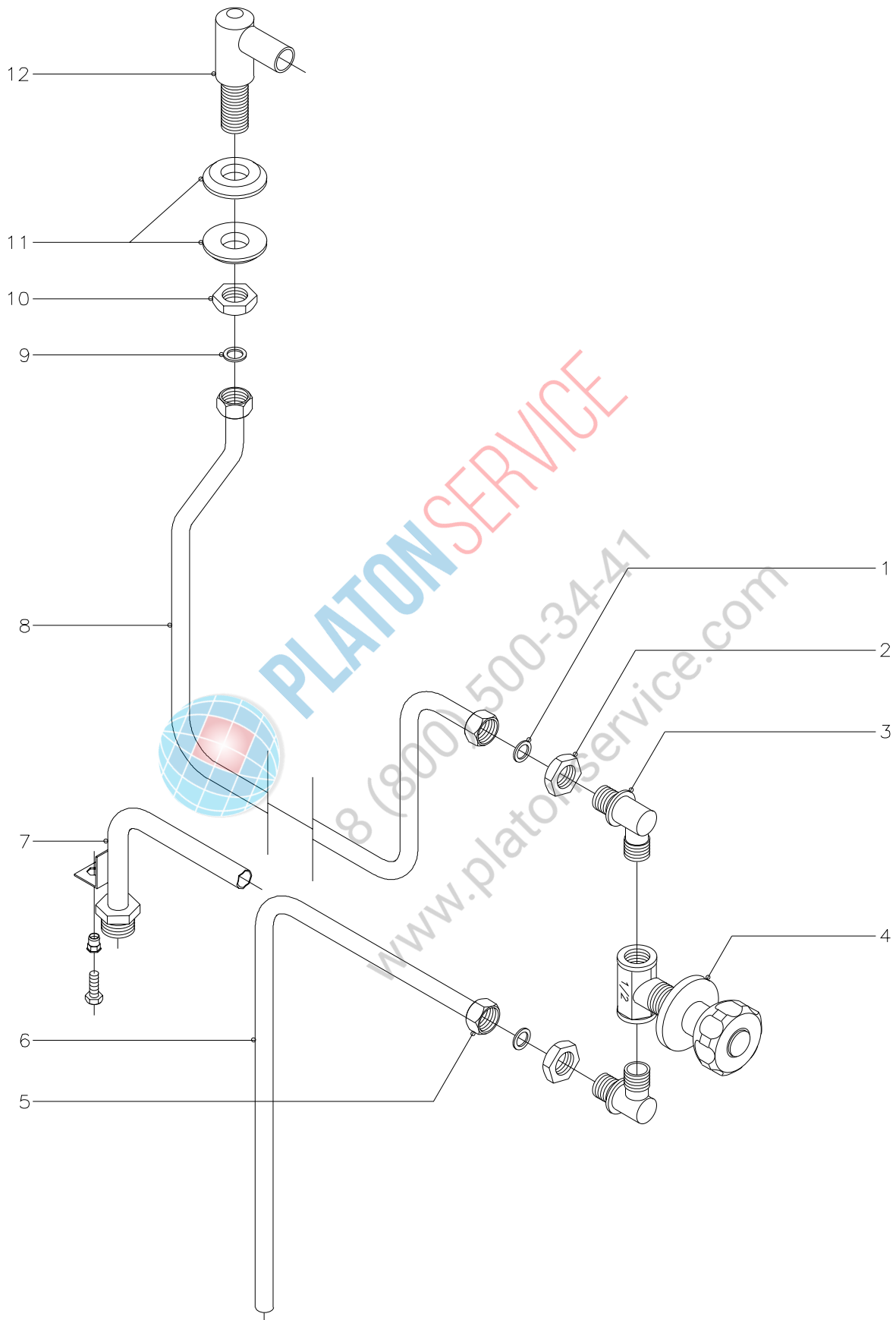

N plano C-659	Firma 	Fecha 1-99	Aparato SARTEN BASCULANTE 900	Laminio 11	Fagor Industrial S.Coop. <b>FAGOR</b>  Ocate
------------------	--	---------------	----------------------------------	---------------	--



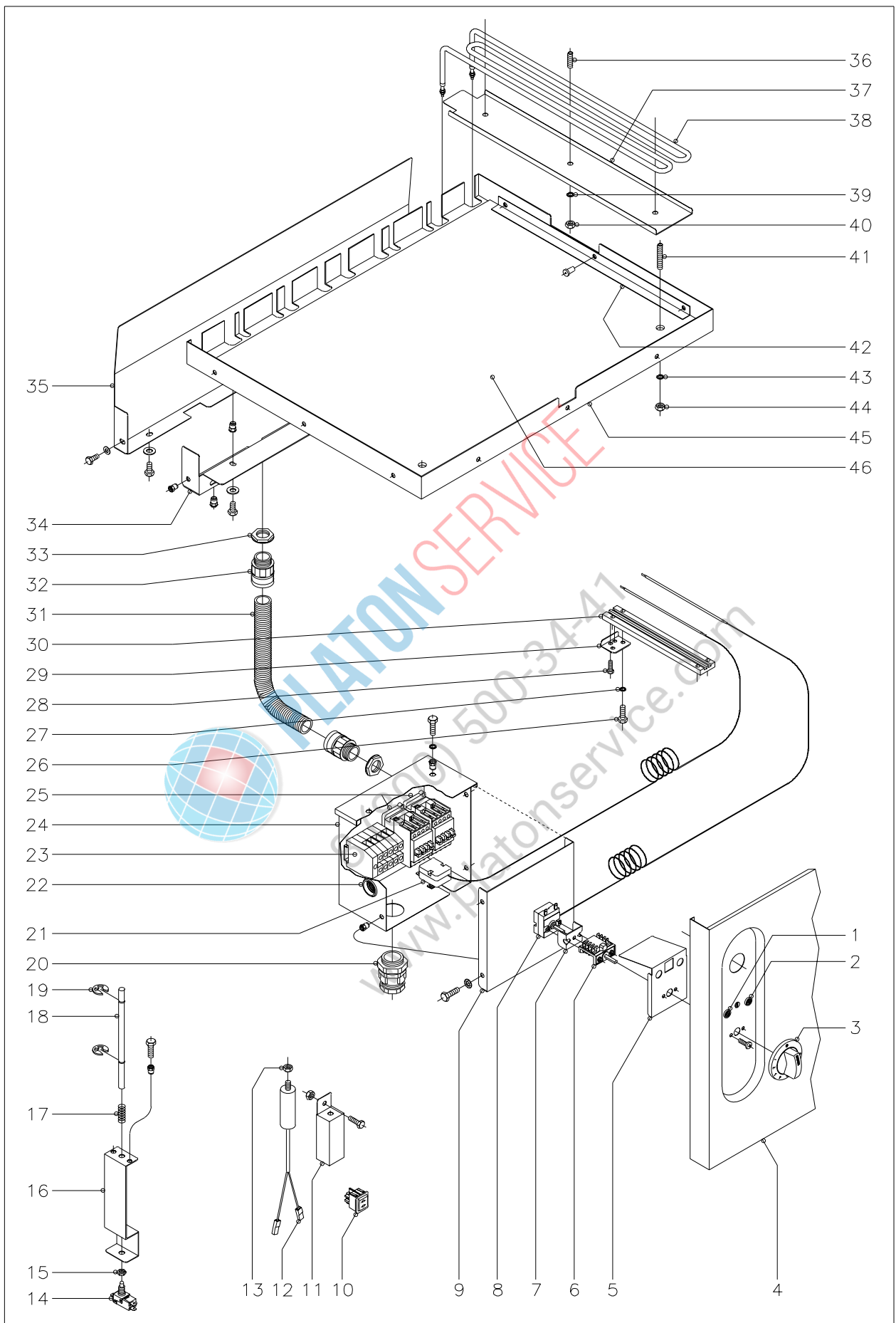

N plano C-660	Firma <i>[Signature]</i>	Fecha 1-99	Aparato SARTEN BASCULANTE 900 ELECT.	Lamina 12	Fagor Industrial S.Coop. <b>FAGOR</b> 0<ate
------------------	-----------------------------	---------------	---	--------------	--



<b>MOD.</b>	<b>SBG9-10</b>	<b>SBE9-10</b>	<b>ZONA</b>	<b>DESPIECE PARTE FUNCIONAL ELECTRICA</b>	<b>PLANO</b>	<b>C-660</b>
	<b>SBG9-15</b>	<b>SBE9-15</b>				
	<b>Versiónes: I, M, S.</b>					

Nº	CODIGO	DENOMINACION	SBE9-10	SBE 9-10 I	SBE 9-10M	SBE 9-10 IM	SBE 9-15 IM	SBE 9-10 S	SBE 9-10 IS	SBE 9-10 MS	SBE 9-10 IMS	SBE 9-15 IMS	NOTAS
1	Z203004	Piloto verde	1	1	1	1	1	1	1	1	1	1	
2	Z203005	Piloto ámbar	1	1	1	1	1	1	1	1	1	1	
3	U673005	Botón de mando Ø 6	1	1	1	1	1	1	1	1	1	1	
4	X142801	Panel frontal	1	1	-	-	-	-	-	-	-	-	
4	X702800	Panel frontal	-	-	1	1	-	-	-	1	1	-	
4	X422800	Panel frontal	-	-	-	-	1	-	-	-	-	1	
4	X252801	Panel frontal	-	-	-	-	-	1	1	-	-	-	
5	X242601	Tapa frontal	1	1	1	1	1	1	1	1	1	1	
6	X163007	Conmutador acople termostato	1	1	1	1	1	1	1	1	1	1	
	Q151320	Tornillo alomado M.4x6	2	2	2	2	2	2	2	2	2	2	
7	X313001	"U" Soporte termostato	1	1	1	1	1	1	1	1	1	1	
8	X153000	Termostato 50-310°C	1	1	1	1	1	1	1	1	1	1	
9	X142616	Tapa de caja contact-regleta	1	1	1	1	1	1	1	1	1	1	
	Q221342	Remache exagonal M.5	2	2	4	4	4	4	4	4	4	4	
	Q242030	Arandela abanico A.5	4	4	4	4	4	4	4	4	4	4	
	Q012032	Tornillo exagonal M.5x15	4	4	4	4	4	4	4	4	4	4	
10	X343002	Interruptor basculante	-	-	1	1	1	-	-	1	1	1	
11	X343004	Cubierta condensador	-	-	1	1	1	-	-	1	1	1	
	Q012031	Tornillo exagonal M.5x10	-	-	1	1	1	-	-	1	1	1	
	Q162030	Tuerca exagonal M.5	-	-	1	1	1	-	-	1	1	1	
12	X343001	Condensador 5 MF.	-	-	1	1	1	-	-	1	1	1	
13	Q161450	Tuerca exagonal M.8	-	-	1	1	1	-	-	1	1	1	
14	X343015	Microrruptor	1	1	2	2	2	1	1	2	2	2	
15	Q222005	Tuerca exagonal M.10x0,75	1	1	2	2	2	1	1	2	2	2	
16	X153006	Soporte eje micro	1	1	2	2	2	1	1	2	2	2	
	Q221342	Remache exagonal M.5	2	2	4	4	4	2	2	4	4	4	
	Q012031	Tornillo exagonal M.5x10	2	2	4	4	4	2	2	4	4	4	
17	Z700603	Muelle	1	1	2	2	2	1	1	2	2	2	
18	X153007	Eje pulsador micro	1	1	2	2	2	1	1	2	2	2	
19	Q271033	Arandela de seguridad Ø 6	2	2	4	4	4	2	2	4	4	4	
20	R033002	Prensaestopas	1	1	1	1	-	1	1	1	1	-	
20	R073004	Prensaestopas	-	-	-	-	1	-	-	-	-	1	

<b>MOD.</b>	<b>SBG9-10</b> <b>SBE9-10</b> <b>SBG9-15</b> <b>SBE9-15</b>  <b>Versiónes: I, M, S.</b>	<b>ZONA</b>	<b>DESPIECE PARTE FUNCIONAL</b> <b>ELECTRICA</b>	<b>PLANO</b>	<b>C-660</b>
-------------	--	-------------	---	--------------	--------------

Nº	CODIGO	DENOMINACION	SBE9-10	SBE 9-10 I	SBE 9-10M	SBE 9-10 IM	SBE 9-15 IM	SBE 9-10 S	SBE 9-10 IS	SBE 9-10 MS	SBE 9-10 IMS	SBE 9-15 IMS	NOTAS
21	R612103	Termostato limitador	1	1	1	1	1	1	1	1	1	1	
	Q223022	Tuerca exagonal M.8x1	1	1	1	1	1	1	1	1	1	1	
22	X723014	Pasamuros Ø 30	2	2	2	2	2	2	2	2	2	2	
23	P453025	Borna fases (gris)	3	3	3	3	-	3	3	3	3	-	
	Z263302	Borna neutro (azul)	1	1	1	1	-	1	1	1	1	-	
	P453026	Borna tierra (amarillo-verde)	1	1	1	1	-	1	1	1	1	-	
	Z263303	Tope final	1	1	1	1	-	1	1	1	1	-	
23	Z683069	Borna fases (gris)	-	-	-	-	3	-	-	-	-	3	
	Z683097	Borna neutro (azul)	-	-	-	-	1	-	-	-	-	1	
	Z683070	Borna tierra (amarillo-verde)	-	-	-	-	1	-	-	-	-	1	
	Z683096	Tope final	-	-	-	-	1	-	-	-	-	1	
24	X142615	Caja contactores-regleta	1	1	1	1	1	1	1	1	1	1	
	Q221343	Remache exagonal M.6	2	2	2	2	2	2	2	2	2	2	
	Q261040	Arandela grower A.6	2	2	2	2	2	2	2	2	2	2	
	Q012042	Tornillo exagonal M.6x15	2	2	2	2	2	2	2	2	2	2	
25	R663031	Contactador 230 V. 50-60 Hz.	2	2	2	2	-	2	2	2	2	-	
25	X183011	Contactador 230 V. 50-60 Hz.	-	-	-	-	2	-	-	-	-	2	
26	Q012042	Tornillo exagonal M.6x15	4	-	4	-	-	4	-	4	-	-	
27	Q262040	Arandela grower A.6	4	-	4	-	-	4	-	4	-	-	
28	Q012031	Tornillo exagonal M.5x10	2	2	2	2	2	2	2	2	2	2	
29	X142626	Tope bulbo termostato	1	-	1	-	-	1	-	1	-	-	
30	X156130	Cubre bulbo	1	-	1	-	-	1	-	1	-	-	
31	X143007	Tubo protección cables	1	1	1	1	1	1	1	1	1	1	
32	X713021	Racord SFNO - P213 T	2	2	2	2	2	2	2	2	2	2	
33	X713022	Tuerca PG-21	2	2	2	2	2	2	2	2	2	2	
34	X142641	Cubierta de bornas	1	1	1	1	-	1	1	1	1	-	
34	X422607	Cubierta de bornas	-	-	-	-	1	-	-	-	-	1	
35	X142642	Tapa cubierta bornas	1	1	1	1	-	1	1	1	1	-	
35	X422606	Tapa cubierta bornas	-	-	-	-	1	-	-	-	-	1	
	Q221342	Remache exagonal M.5	8	8	8	8	10	8	8	8	8	10	
	Q302022	Arandela plana Ø16xØ6x1,2	8	8	8	8	10	8	8	8	8	10	

**MOD.****SBG9-10  
SBG9-15****SBE9-10  
SBE9-15****Versiónes: I, M, S.****ZONA****DESPIECE PARTE FUNCIONAL  
ELECTRICA****PLANO****C-660**

Nº	CODIGO	DENOMINACION	SBE9-10	SBE 9-10 I	SBE 9-10M	SBE 9-10 IM	SBE 9-15 IM	SBE 9-10 S	SBE 9-10 IS	SBE 9-10 MS	SBE 9-10 IMS	SBE 9-15 IMS	NOTAS
	Q012032	Tornillo exagonal M.5x15	8	8	8	8	10	8	8	8	8	10	
36	Q131555	Varilla roscada M.8x30	14	14	14	14	21	14	14	14	14	21	
37	X142620	Amarre resistencias	6	6	6	6	9	6	6	6	6	9	
38	X143010	Resistencia (230V. 2000W.)	6	6	6	6	9	6	6	6	6	9	
39	Q262050	Arandela grower A.8	18	18	18	18	27	18	18	18	18	27	
40	Q162050	Tuerca exagonal M.8	18	18	18	18	27	18	18	18	18	27	
41	Q131558	Varilla roscada M.8x60	4	4	4	4	6	4	4	4	4	6	
42	X142609	Amarre aislante	3	3	3	3	6	3	3	3	3	6	
	Q419005	Remache tubular Ø4x8	9	9	9	9	18	9	9	9	9	18	
43	Q262050	Arandela grower A.8	4	4	4	4	6	4	4	4	4	6	
44	Q162050	Tuerca exagonal M.8	4	4	4	4	6	4	4	4	4	6	
45	X142640	Cubierta resistencias	1	1	1	1	-	1	1	1	1	-	
45	X422602	Cubierta resistencias	-	-	-	-	1	-	-	-	-	1	
46	X142643	Aislante cubierta	1	1	1	1	-	1	1	1	1	-	
46	X422605	Aislante cubierta	-	-	-	-	2	-	-	-	-	2	

<b>MOD.</b>	<table border="1" style="width:100%; border-collapse: collapse;"> <tr> <td style="text-align: center;"><b>SBG9-10</b> <b>SBG9-15</b></td> <td style="text-align: center;"><b>SBE9-10</b> <b>SBE9-15</b></td> </tr> <tr> <td colspan="2" style="text-align: center;">Versiones: I, M, S.</td> </tr> </table>	<b>SBG9-10</b> <b>SBG9-15</b>	<b>SBE9-10</b> <b>SBE9-15</b>	Versiones: I, M, S.		<b>ZONA</b> <table border="1" style="width:100%; border-collapse: collapse;"><tr><td style="text-align: center;">VARIOS</td></tr></table>	VARIOS	<b>PLANO</b> <table border="1" style="width:100%; border-collapse: collapse;"><tr><td style="width:100px; height:20px;"></td></tr></table>	
<b>SBG9-10</b> <b>SBG9-15</b>	<b>SBE9-10</b> <b>SBE9-15</b>								
Versiones: I, M, S.									
VARIOS									

N°	CODIGO	DENOMINACION	SBG9-10	SBG 9-10 I	SBG 9-10M	SBG 9-10 IM	SBG 9-15 IM	SBG 9-10 S	SBG 9-10 IS	SBG 9-10 MS	SBG 9-10 IMS	SBG 9-15 IMS	NOTAS
	X343018	Instalación eléctrica	1	1	1	1	1	1	1	1	1	1	
	R093004	Cableado auxiliar micro	1	1	1	1	1	1	1	1	1	1	
	U333003	Cable masa encendedor	1	1	1	1	1	1	1	1	1	1	
	U323007	Cable encendedor a bujía	1	1	1	1	1	1	1	1	1	1	
	X343016	Cableado auxiliar motor	-	-	1	1	1	-	-	1	1	1	
	X153011	Esquema eléctrico	1	1	-	-	-	1	1	-	-	-	(HB-14.900)
	X343005	Esquema eléctrico	-	-	1	1	1	-	-	1	1	1	(HB-70.600)
	X153010	Esquema montaje	1	1	-	-	-	1	1	-	-	-	(HC-71.111)
	X343006	Esquema montaje	-	-	1	1	1	-	-	1	1	1	(HC-72.509)
	X156501	Folleto de instrucciones	1	1	1	1	1	1	1	1	1	1	
	X343012	Cable desembrague	-	-	1	1	1	-	-	1	1	1	
	X280107	Soporte cable desembrague	-	-	1	1	1	-	-	1	1	1	

MOD.

SBG9-10  
SBG9-15

SBE9-10  
SBE9-15

Versiónes: I, M, S.

ZONA

VARIOS

PLANO

Nº	CODIGO	DENOMINACION	SBE9-10	SBE 9-10 I	SBE 9-10M	SBE 9-10 IM	SBE 9-15 IM	SBE 9-10 S	SBE 9-10 IS	SBE 9-10 MS	SBE 9-10 IMS	SBE 9-15 IMS	NOTAS
	X143011	Cableado portamandos	1	1	1	1	1	1	1	1	1	1	
	X143004	Cableado resistencias	1	1	1	1	-	1	1	1	1	-	
	X423004	Cableado resistencias	-	-	-	-	1	-	-	-	-	1	
	X383007	Cableado regleta-contactores	1	1	1	1	-	1	1	1	1	-	
	X423000	Cableado regleta-contactores	-	-	-	-	1	-	-	-	-	1	
	X343016	Cableado auxiliar motor	-	-	1	1	1	-	-	1	1	1	
	X143002	Esquema eléctrico	1	1	-	-	-	1	1	-	-	-	(HC-71.588)
	X403000	Esquema eléctrico	-	-	1	1	-	-	-	1	1	-	(HC-72.725)
	X423001	Esquema eléctrico	-	-	-	-	1	-	-	-	-	1	(HC-74.336)
	X143003	Esquema montaje	1	1	-	-	-	1	1	-	-	-	(HC-71.789)
	X403001	Esquema montaje	-	-	1	1	-	-	-	1	1	-	(HC-72.728)
	X423002	Esquema montaje	-	-	-	-	1	-	-	-	-	1	(HC-74.343)
	X146505	Folleto de instrucciones	1	1	1	1	1	1	1	1	1	1	
	X343012	Cable desembrague	1	1	1	1	1	1	1	1	1	1	
	X280107	Soporte cable desembrague	-	-	1	1	1	-	-	1	1	1	

MOD.

SBG9-10  
SBG9-15SBE9-10  
SBE9-15

Versiones: I, M, S.

ZONA

PIEZAS ESPECIFICAS PARA  
LOS DISTINTOS GASES

PLANO

C-657

Nº	CODIGO	DENOMINACION	SBG9-10	SBG 9-10 I	SBG 9-10M	SBG 9-10 IM	SBG 9-15 IM	SBG 9-10 S	SBG 9-10 IS	SBG 9-10 MS	SBG 9-10 IMS	SBG 9-15 IMS	NOTAS
		<b>BUTANO - PROPANO</b>											
5	U052401	Tobera Ø 1,45	2	2	2	2	3	2	2	2	2	3	
s/n	U136501	Indicador (Butano-Propano)	1	1	1	1	1	1	1	1	1	1	
		<b>GAS NATURAL</b>											
5	U262400	Tobera Ø 2,15	2	2	2	2	3	2	2	2	2	3	
s/n	U134402	Indicador (Gas Natural)	1	1	1	1	1	1	1	1	1	1	
		<b>GAS VILLA</b>											
5	X102403	Tobera Ø 4,58	2	2	2	2	3	2	2	2	2	3	
s/n	U134310	Indicador (Gas Villa)	1	1	1	1	1	1	1	1	1	1	

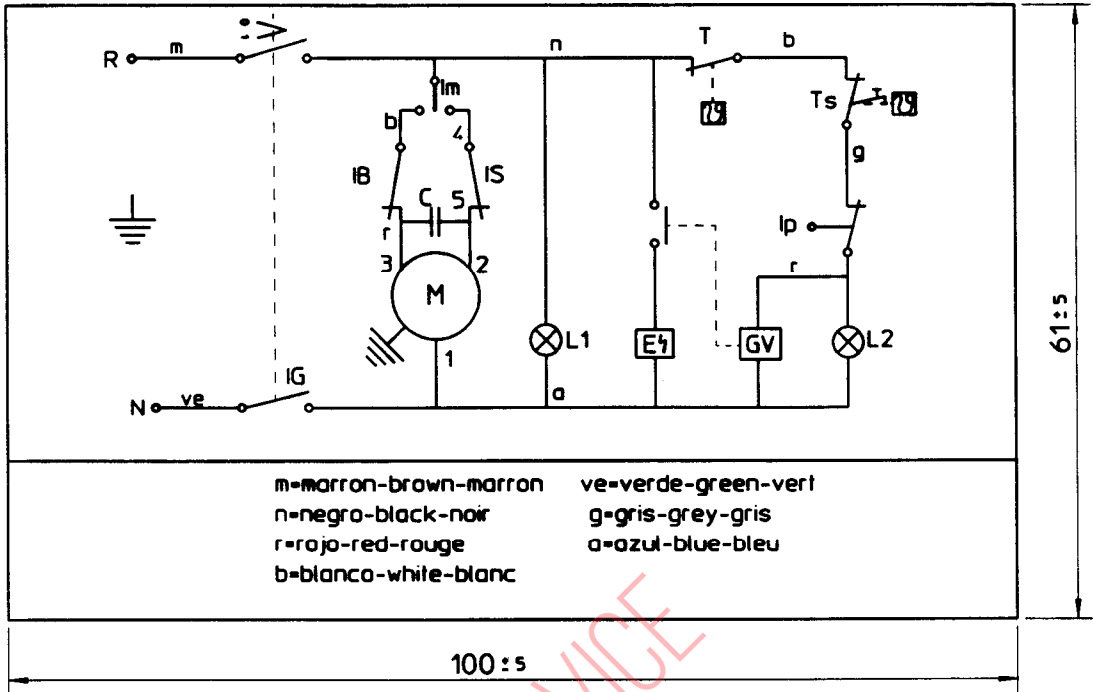

m=marron-brown-marron    ve=verde-green-vert  
n=negro-black-noir        g-gris-grey-gris  
r=rojo-red-rouge            a=azul-blue-bleu  
b=blanco-white-blanc

- Im = Pulsador Subida/Bajada
- M = Moto reductor 0.27 r.p.m.
- C = Condensador 5 $\mu$ F
- IG = Interruptor general
- L1 = Lampara funcionamiento
- T = Termostato regulable (50-310°C)
- Ip = Micro elevación
- L2 = Lampara calentamiento
- E = Encendedor
- GV = Grifo valvula gas
- Ts = Termostato seguridad (400°C)
- Is = Micro tope subida
- Ib = Micro tope bajada

**NOTAS:**

- GRABACIONES: COLOR NEGRO
- FONDO: COLOR NATURAL
- LA PLACA SERA AUTOADHESIVA POR LA CARA POSTERIOR Y RECUBIERTO POR UN PAPEL PROTECTOR.
- LAS INSCRIPCIONES RESISTIRAN SIN MODIFICACION APRECIABLE. EL FROTAMIENTO DURANTE 15 SEG. DE UN ALGODON EMPAPADO EN GASOLINA.

Esquema teorico adhesivo SBG-910 IM		Poliester mate	X-343005			
Nº	Pieza	Material	Nº Clasificacion	Acabado		
Nº	Modificacion	Propuesta de	Fecha	Tolerancias generales		
				< 5 ±	50-100±	
				5 - 25±	> 100±	
				25 - 50±	OX ±	
	Firma	Fecha	 Fagor Industrial, Koop, Elk, Mugatua			
	Dibujado	JON				94-11-23
	Proyectado					
	Comprobado	<i>Letoua</i>				
	Escala	SBG-910 I MOTOR			Plano numero	HB-70600
					Sustituye al Nº	

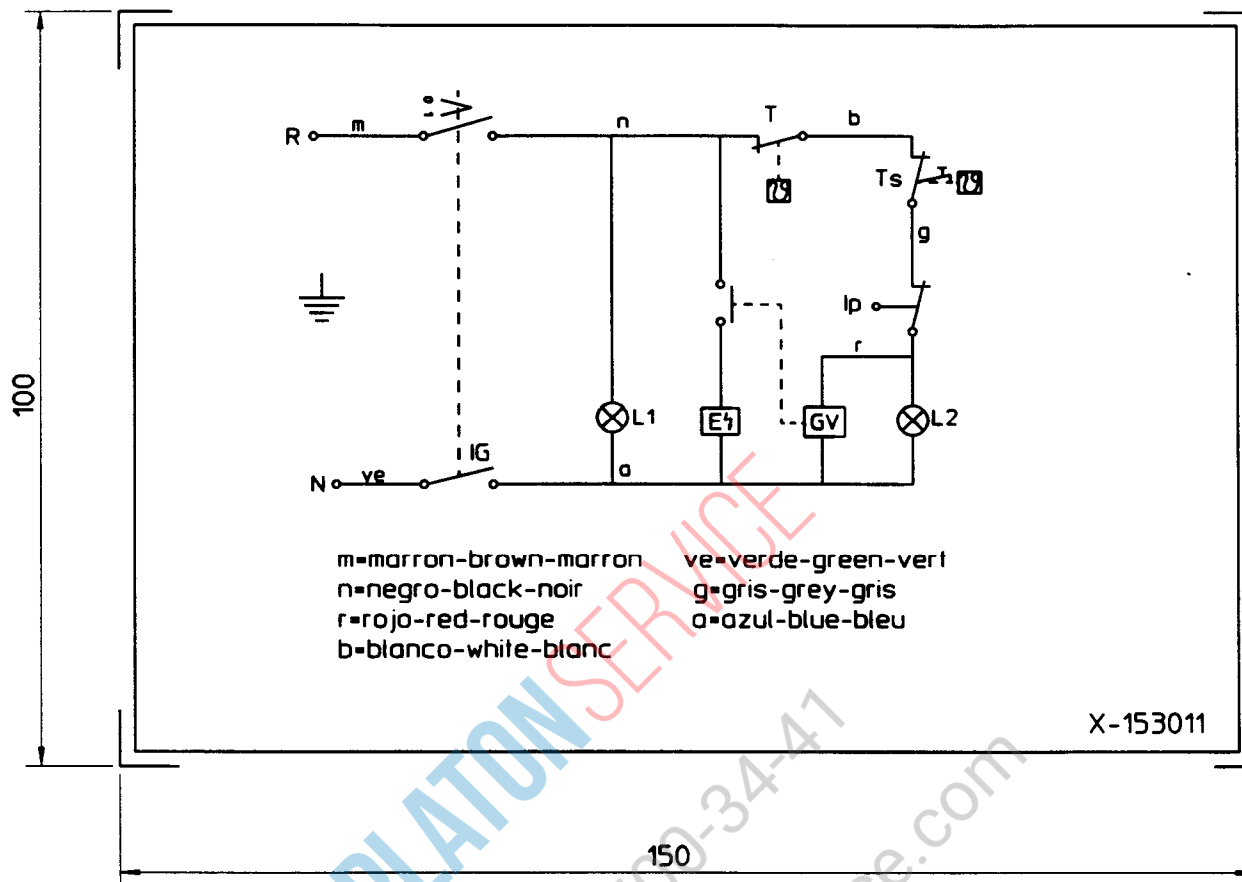

NOTA: - LAS INSCRIPCIONES RESISTIRAN SIN MODIFICACION APRECIABLE, EL FROTAMIENTO DURANTE 15 SEG. DE UN ALGODON EMPAPADO EN GASOLINA.

- IG - Interruptor general
- L1 - Lampara funcionamiento
- T - Termostato regulable (50-310°C)
- Ip - Micro elevación
- L2 - Lampara calentamiento
- E - Encendedor
- GV - Grifo valvula gas
- Ts - Termostato seguridad (400°C)

Plastico blanco alto brillo

Esquema teorico adhesivo SBG-910		X-153011	
Nº	Pieza	Material	Nº Clasificacion
Nº	Modificacion	Propuesta de	Fecha
1	Modif.general(pasar a fabric.interior)	Plazaola	22-4-97
			Tolerancias generales
			< 5 ±                      50÷100±
			5 ÷ 25±                    > 100±
			25 ÷ 50±                    ∅ ±
Firma	Fecha	 Fagor Industrial.Koop.Elk, Mugatua	
Dibujado	JON    94-11-23		
Proyectado			
Comprobado	<i>Leturia</i>		
Escala	SARTEN BASCULANTE		Plano numero HB-14900-1
			Sustituye al Nº







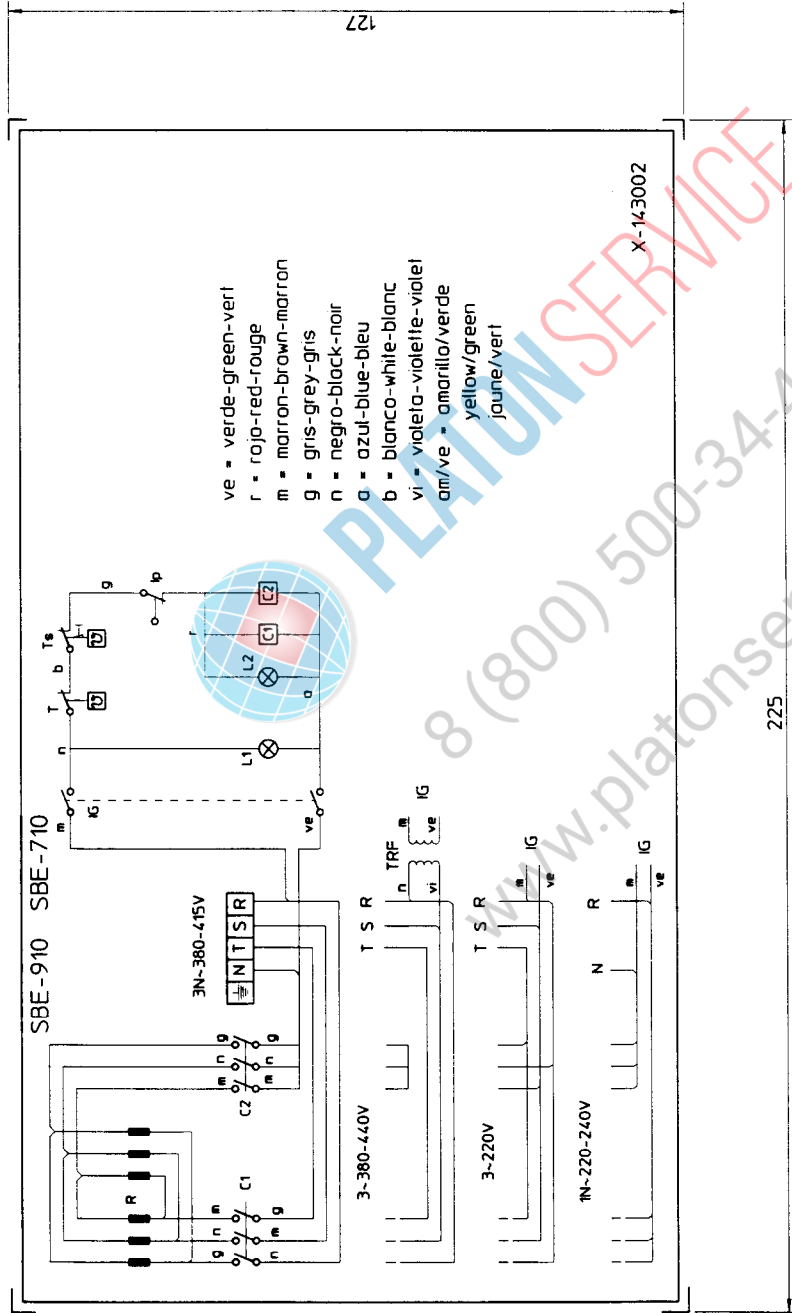

Plastico blanco alto brillo

NOTAS  
 - Las inscripciones resistirán sin modificación apreciable el tratamiento durante 15 seg. de un algodón impregnado en gasolina.

- IG: Interruptor general
- L1: Lámpara funcionamiento
- T: Termostato regulable (50-310°C)
- L2: Lámpara calentamiento
- C1, C2: Contactor de calentamiento
- R: Resistencias
- P: Micro de Seguridad
- TS: Termostato Seguridad (400°)
- TRF: Transformador

Esquema teorico		X-143002	
Nº Piezo	Material	Nº Clasificación	Acabado
Propuesta de		Tolerancias generales	
1 Modific. general (pasar a fabri. interior)	Plazaola	Fecha	< 5°
2 Introducir SBE-710	Elxeberrya	Fecha	5-75°
			75-50°
Firma		Fecha	
Plazaola		21-4-97	
Proyectado			
Comprobado			
Escala			
1/1		FAGOR	
		Fagor IndustrialKoopElk. Mugatua	
		Mecanizado superficial	
		Plano numero	
		HC-71588-2	
		Sustituye al Nº	
		Sustituido por	

Plano hau ez daiteke erabili ez berria gure baimentz gabe

SOLO VERSION MOTOR DE ELEVACION

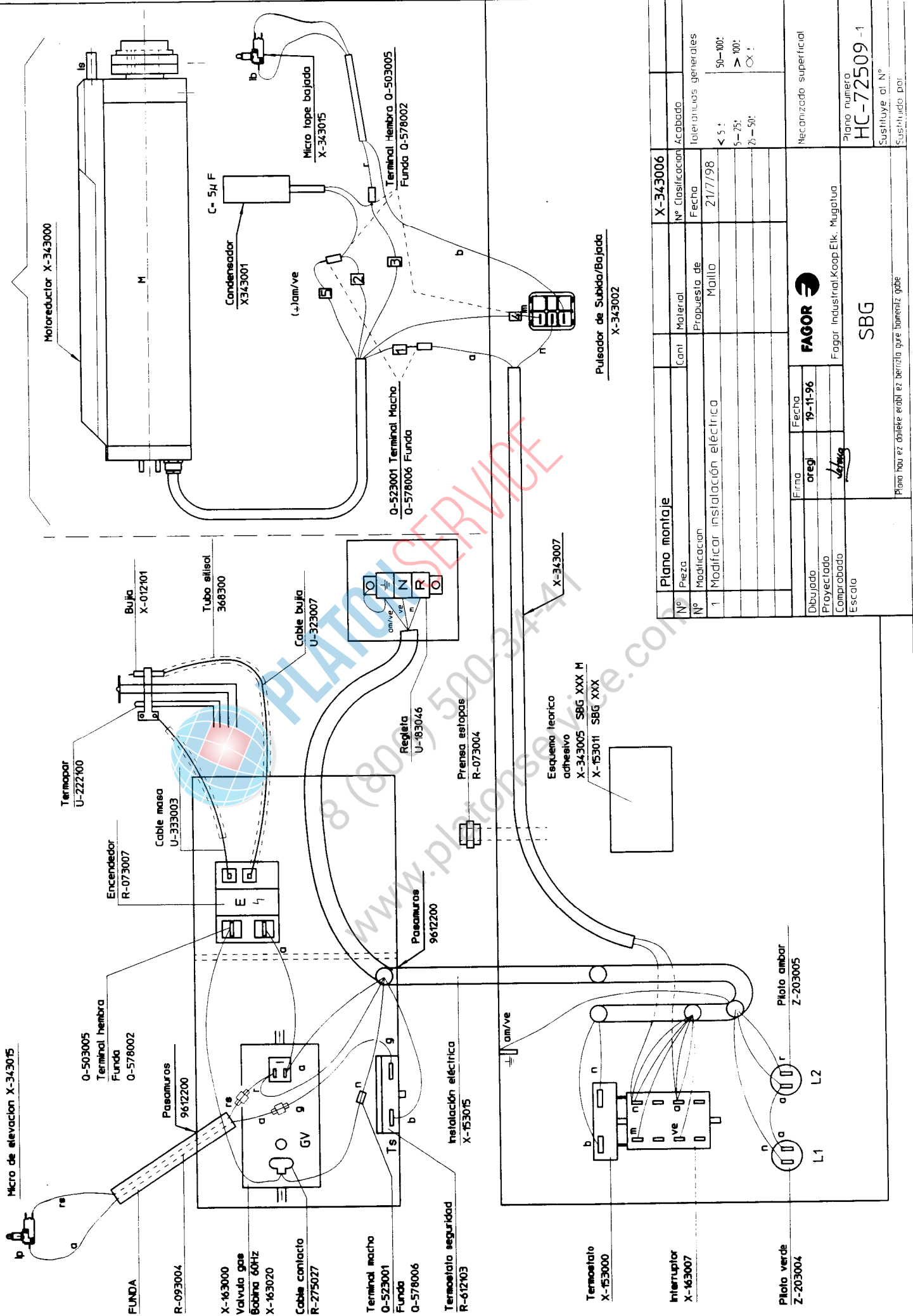

Plano montaje		X-343006	
Nº Pieza		Cant	Material
Nº Modificacion			Propuesta de
1	Modificar instalación eléctrica		Malla
Tolerancias generales			
< 5°			
5-25°			
25-50°			
50-100°			
> 100°			
OX!			
Recomendado superficial			
Firma		Fecha	
oreg		19-11-96	
Dibujado		FAGOR	
Proyectado		Fagor Industrial Koop Elk. Mugatua	
Comprobado			
Escala		SBG	
Plano numero			
HC-72509-1			
Sustituye al Nº			
Sustituido por			

Plano hau ez daiteke erabili ez bertizio gure baimeniz gabe







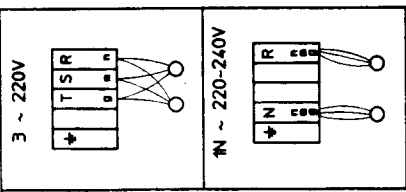
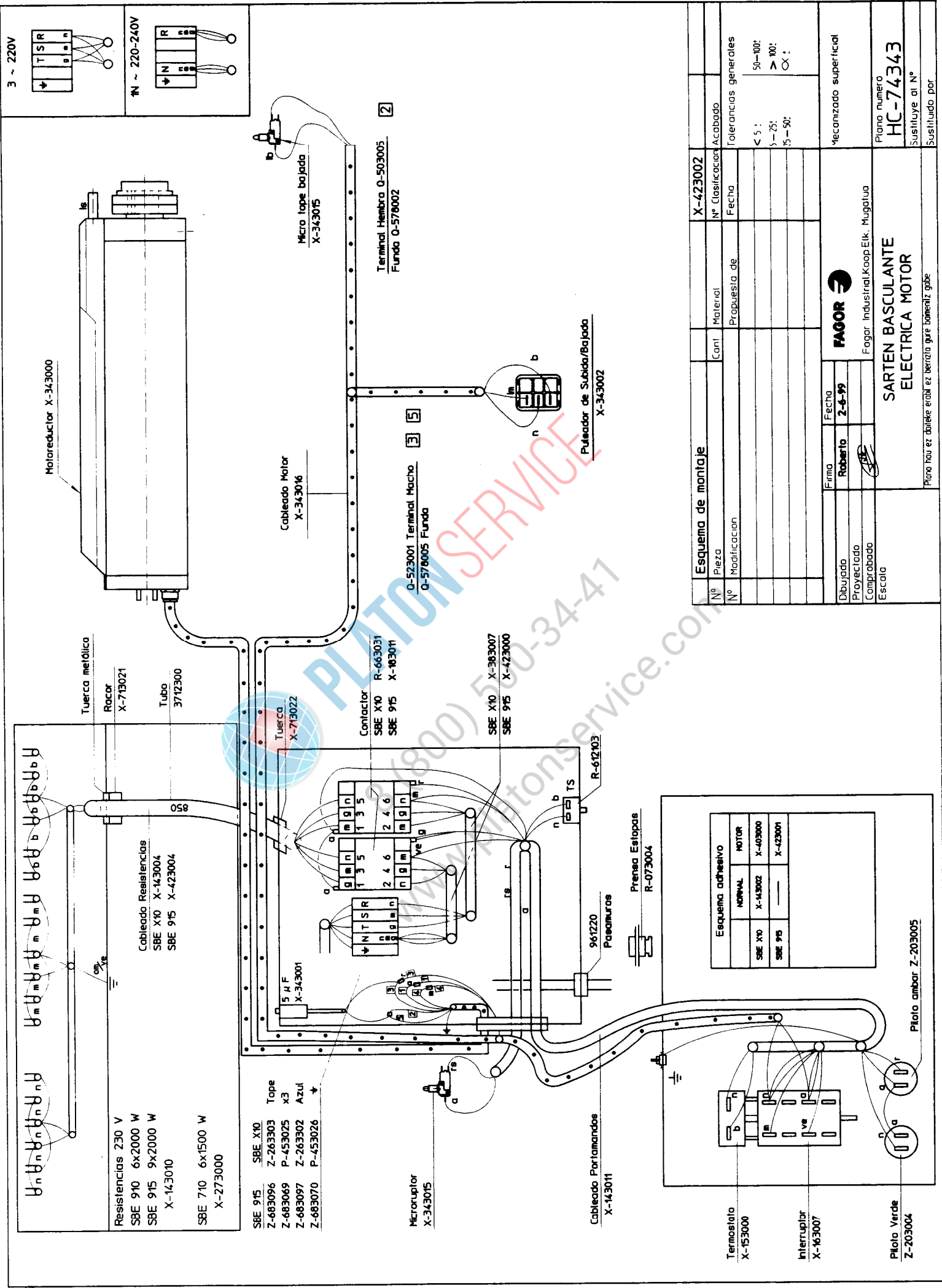

- Resistencias 230 V  
SBE 910 6x2000 W  
SBE 915 9x2000 W  
X-143010
- SBE 710 6x1500 W  
X-273000
- SBE 915 SBE X10  
Z-663096 Z-263303  
Z-663069 P-453025 x3  
Z-663097 Z-263302 Azul  
Z-663070 P-453026 ↓
- Tape  
Z-663096 Z-263303  
P-453025 x3  
Z-263302 Azul  
P-453026 ↓
- Resistencias  
SBE X10 X-143004  
SBE 915 X-423004
- Tuerca metálica  
Racor X-713021  
Tubo 3712300
- Tuerca X-713022
- Contactor  
SBE X10 R-663031  
SBE 915 X-163011
- SBE X10 X-363007  
SBE 915 X-423000
- Micro interruptor X-343015
- Cableado Portamandos X-143011
- 961220 Pasamuros
- Prensa Estopas R-073004
- Esquema adhesivo  
NORMAL MOTOR  
SBE X10 X-143002 X-403000  
SBE 915 X-423001
- Termosifón X-153000
- Interruptor X-163007
- Plata Verde Z-203004
- Plata ambar Z-203005
- 95

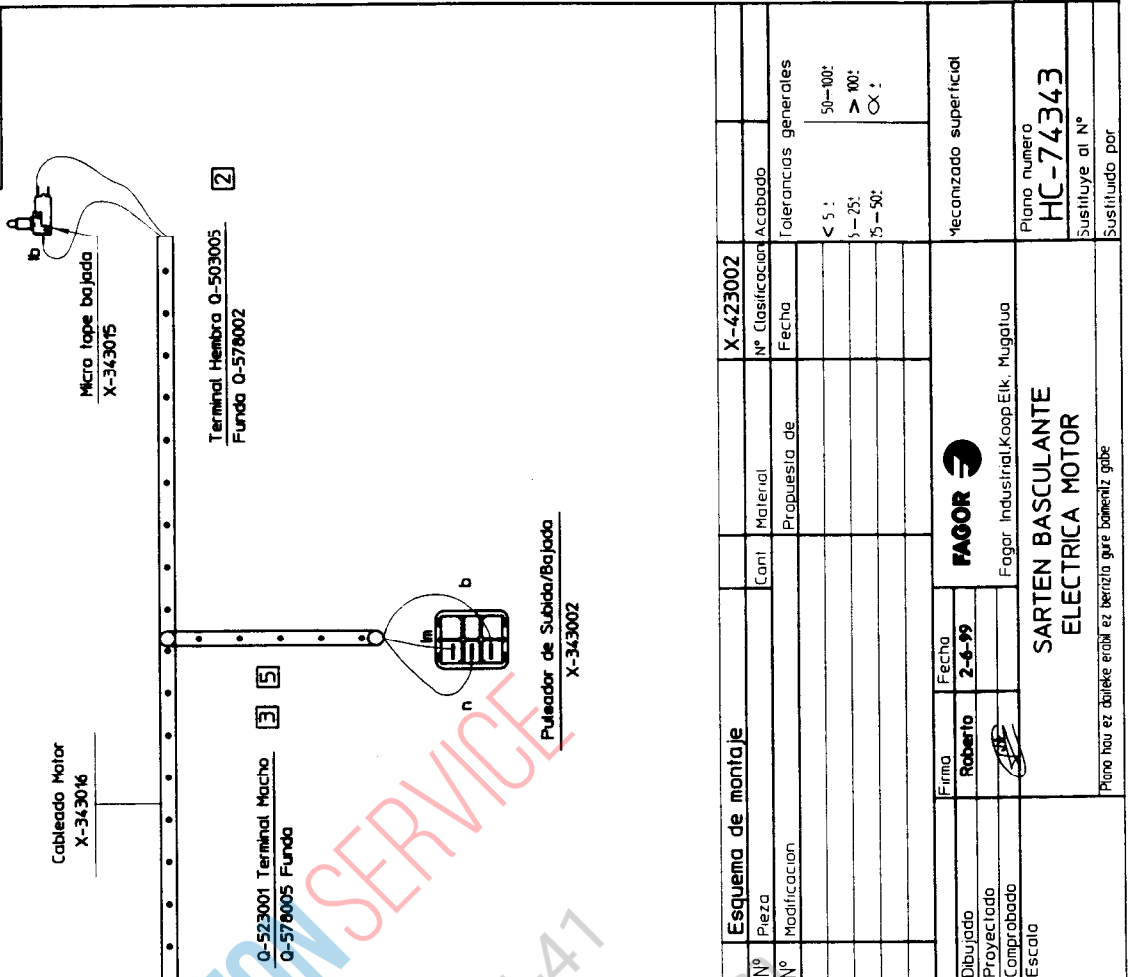

Esquema de montaje		X-423002		Acabado	
Nº Pieza	Cant.	Material	Nº Clasificación	Fecha	Tolerancias generales
Nº Modificación		Propuesta de			< 5 : 5-25 : 25-50 :
					50-100: > 100: ∞ :
<b>FAGOR</b>					
Dibujado	Firma	Fecha	Mecanizado superficial		
Proyectado	Roberto	2-6-99			
Comprobado					
Escalfo					
Fagor Industrial Koop. Elk. Mugatua					
<b>SARTEN BASCULANTE ELECTRICA MOTOR</b>					
Plano numero <b>HC-74343</b>					
Sustituye al Nº					
Sustituido por					

Plano hau ez daiteke erabili ez bertizia gure baimeniz gabe